

# User Manual

## 3-Phase PV Grid-Connected Inverter

SG3.0RT / SG4.0RT / SG5.0RT / SG6.0RT / SG7.0RT /  
SG8.0RT / SG10RT / SG12RT / SG15RT / SG17RT /  
SG20RT / SG5.0RT-P2 / SG6.0RT-P2 / SG7.0RT-P2 /  
SG8.0RT-P2 / SG10RT-P2 / SG12RT-P2 / SG15RT-P2 /  
SG17RT-P2 / SG20RT-P2



---

# All Rights Reserved

## **All Rights Reserved**

No part of this document can be reproduced in any form or by any means without the prior written permission of Sungrow Power Supply Co., Ltd (hereinafter "SUNGROW").

## **Trademarks**

**SUNGROW** and other SUNGROW trademarks used in this manual are owned by SUNGROW.

All other trademarks or registered trademarks mentioned in this manual are owned by their respective owners.

## **Software Licenses**

- It is prohibited to use data contained in firmware or software developed by SUNGROW, in part or in full, for commercial purposes by any means.
- It is prohibited to perform reverse engineering, cracking, or any other operations that compromise the original program design of the software developed by SUNGROW.

# About This Manual

The manual mainly contains the product information, as well as guidelines for installation, operation, and maintenance. The manual does not include complete information about the photovoltaic (PV) system. Readers can get additional information at [www.sungrowpower.com](http://www.sungrowpower.com) or on the webpage of the respective component manufacturer.

## Validity

This manual is valid for the following model of low-power grid-connected PV string inverters:

- SG3.0RT
- SG4.0RT
- SG5.0RT
- SG6.0RT
- SG7.0RT
- SG8.0RT
- SG10RT
- SG12RT
- SG15RT
- SG17RT
- SG20RT
- SG5.0RT-P2
- SG6.0RT-P2
- SG7.0RT-P2
- SG8.0RT-P2
- SG10RT-P2
- SG12RT-P2
- SG15RT-P2
- SG17RT-P2
- SG20RT-P2

It will be referred to as "inverter" hereinafter unless otherwise specified.

## Target Group

This manual is intended for professional technicians who are responsible for installation, operation, and maintenance of inverters, and users who need to check inverter parameters.

The inverter must only be installed by professional technicians. The professional technician is required to meet the following requirements:

- Know electronic, electrical wiring and mechanical expertise, and be familiar with electrical and mechanical schematics.

- Have received professional training related to the installation and commissioning of electrical equipment.
- Be able to quickly respond to hazards or emergencies that occur during installation and commissioning.
- Be familiar with local standards and relevant safety regulations of electrical systems.
- Read this manual thoroughly and understand the safety instructions related to operations.

### **How to Use This Manual**

Please read this manual carefully before using the product and keep it properly at a place for easy access.

All contents, pictures, marks, and symbols in this manual are owned by SUNGROW. No part of this document may be reprinted by the non-internal staff of SUNGROW without written authorization.

Contents of this manual may be periodically updated or revised, and the actual product purchased shall prevail. Users can obtain the latest manual from [support.sungrowpower.com](https://support.sungrowpower.com) or sales channels.

### **Security Declaration**

For details on the product's network security vulnerability response process and vulnerability disclosure, please visit the following website: <https://en.sungrowpower.com/security-vulnerability-management>.

For more information on network security, please refer to the user manual of the communication module or the Data Logger that comes with the product.

### **Symbols**

This manual contains important safety instructions, which are highlighted with the following symbols, to ensure personal and property safety during usage, or to help optimize the product performance in an efficient way.

Please carefully understand the meaning of these warning symbols to better use the manual.

#### **DANGER**

**Indicates high-risk potential hazards that, if not avoided, may lead to death or serious injury.**

#### **WARNING**

**Indicates moderate-risk potential hazards that, if not avoided, may lead to death or serious injury.**

**⚠ CAUTION**

Indicates low-risk potential hazards that, if not avoided, may lead to minor or moderate injury.

**NOTICE**

Indicates potential risks that, if not avoided, may lead to device malfunctions or financial losses.

“NOTE” indicates additional information, emphasized contents or tips that may be helpful, e.g., to help you solve problems or save time.

# Contents

---

All Rights Reserved.....	I
About This Manual.....	II
<b>1 Safety Instructions.....</b>	<b>1</b>
1.1 Unpacking and Inspection.....	2
1.2 Installation Safety.....	3
1.3 Electrical Connection Safety.....	3
1.4 Operation Safety.....	5
1.5 Maintenance Safety.....	6
1.6 Disposal Safety.....	7
<b>2 Product Description.....</b>	<b>8</b>
2.1 System Introduction.....	8
2.2 Product Introduction.....	10
2.3 Symbols on Product.....	12
2.4 LED Indicator.....	13
2.5 Circuit Diagram.....	14
2.6 Function Description.....	15
<b>3 Unpacking and Storage.....</b>	<b>22</b>
3.1 Unpacking and Inspection.....	22
3.2 Inverter Storage.....	22
<b>4 Mechanical Mounting.....</b>	<b>24</b>
4.1 Safety During Mounting.....	24
4.2 Location Requirements.....	25
4.2.1 Installation Environment Requirements.....	26
4.2.2 Carrier Requirements.....	28
4.2.3 Angle Requirements.....	28
4.2.4 Clearance Requirements.....	29
4.3 Installation Tools.....	30
4.4 Moving the Inverter.....	31
4.5 Installing the Inverter.....	32
4.6 Installing Optimizer(Optional).....	34
<b>5 Electrical Connection.....</b>	<b>35</b>
5.1 Safety Instructions.....	35
5.2 Terminal Description.....	37
5.3 Electrical Connection Overview.....	39

5.4 External Protective Grounding Connection.....	41
5.4.1 External Protective Grounding Requirements.....	42
5.4.2 Connection Procedure.....	42
5.5 AC Cable Connection.....	44
5.5.1 AC Side Requirements.....	44
5.5.2 Assembling the AC Connector (< 15 kW).....	45
5.5.3 Installing the AC Connector (< 15 kW).....	47
5.5.4 Assembling the AC Connector ( $\geq$ 15 kW).....	48
5.5.5 Installing the AC Connector ( $\geq$ 15 kW).....	50
5.6 DC Cable Connection.....	52
5.6.1 PV Input Configuration.....	54
5.6.2 Assembling PV Connectors.....	55
5.6.3 Installing the PV Connectors.....	56
5.7 WiNet-S/WiNet-S2 Connection.....	60
5.7.1 Ethernet Communication.....	61
5.7.2 WLAN Communication.....	63
5.8 WiFi-P2 Connection (for Brazil).....	63
5.9 Meter Connection.....	64
5.9.1 Assembling the COM Connector.....	64
5.9.2 Installing the COM Connector.....	66
5.10 RS485 Connection.....	67
5.10.1 RS485 Communication System.....	67
5.10.2 Assembling the COM Connector.....	68
5.10.3 Installing the COM Connector.....	71
5.11 DO Connection.....	72
5.12 DRM Connection.....	72
5.13 DI Connection.....	73
5.14 NS Protection Connection.....	76
<b>6 Commissioning.....</b>	<b>81</b>
6.1 Inspection Before Commissioning.....	81
6.2 Powering on the System.....	81
6.3 App Preparation.....	82
6.4 Plant Creation.....	82
6.5 Optimizer Physical Layout (Optional).....	90
<b>7 iSolarCloud App.....</b>	<b>91</b>
7.1 About iSolarCloud.....	91
7.2 Install iSolarCloud.....	92
7.3 User Roles.....	93
7.4 Device Commissioning.....	93

<b>8 System Decommissioning</b> .....	94
8.1 Disconnecting the Inverter.....	94
8.2 Dismantling the Inverter.....	94
8.3 Disposal of Inverter.....	95
<b>9 Troubleshooting and Maintenance</b> .....	96
9.1 Troubleshooting.....	96
9.2 Maintenance.....	104
9.2.1 Maintenance Notices.....	104
9.2.2 Quick Shutdown.....	105
9.2.3 Routine Maintenance.....	106
9.2.4 Fan Maintenance.....	106
<b>10 Appendix</b> .....	109
10.1 Technical Data.....	109
10.2 Quality Assurance.....	141
10.3 Contact Information.....	142

# 1 Safety Instructions

When installing, commissioning, operating, and maintaining the product, strictly observe the labels on the product and the safety requirements in the manual. Incorrect operation or work may cause:

- Injury or death to the operator or a third party.
- Damage to the product and other properties.

## WARNING

- **Do not perform any operation on the product (including but not limited to, handling, installing, powering on, or maintaining the product, performing electrical connection, and working at heights) in harsh weather conditions, such as thunder and lightning, rain, snow, and Level 6 or stronger winds. SUNGROW shall not be held liable for any damage to the device due to force majeure, such as earthquakes, floods, volcanic eruptions, mudslides, lightning strikes, fires, wars, armed conflicts, typhoons, hurricanes, tornadoes, and other extreme weathers.**
- **In case of fire, evacuate from the building or product area and call the fire alarm. Re-entry into the burning area is strictly prohibited under any circumstances.**

## NOTICE

- **Tighten the screws with the specified torque using tools when fastening the product and terminals. Otherwise, the product may be damaged. And the damage caused is not covered by the warranty.**
- **Learn how to use tools correctly before using them to avoid hurting people or damaging the device.**
- **Maintain the device with sufficient knowledge of this manual and use proper tools.**

- The safety instructions in this manual are only supplements and cannot cover all the precautions that should be followed. Perform operations considering actual onsite conditions.
- SUNGROW shall not be held liable for any damage caused by violation of general safety operation requirements, general safety standards, or any safety instruction in this manual.
- When installing, operating, and maintaining the product, comply with local laws and regulations. The safety precautions in this manual are only supplements to local laws and regulations.
- During the product transport, installation, wiring, maintenance, etc., the materials and tools prepared by users must meet the requirements of applicable local laws and regulations, safety standards, and other specifications. SUNGROW shall not be held liable for any damage to the product caused by the adoption of materials and tools that fail to meet the above-mentioned requirements.
- Operations on the product, including but not limited to, handling, installing, wiring, powering on, maintenance, and use of the product, must not be performed by unqualified personnel. SUNGROW shall not be held liable for any damage to the product resulting from operations done by unqualified personnel.
- Where the transport of the product is arranged by users, SUNGROW shall not be held liable for any damage to the product that is caused by users themselves or the third-party transport service providers designated by the users.
- SUNGROW shall not be held liable for any damage to the product caused by the negligence, intent, fault, improper operation, and other behaviors of users or third-party organizations.
- SUNGROW shall not be held liable for any damage to the product arising from reasons unrelated to SUNGROW.

## 1.1 Unpacking and Inspection

### **WARNING**

- **Check all safety signs, warning labels and nameplates on devices.**
- **The safety signs, warning labels and nameplates must be clearly visible and cannot be removed or covered before the device is decommissioned.**

**NOTICE**

After receiving the product, check whether the appearance and structural parts of the device are damaged, and check whether the packing list is consistent with the actual ordered product. If there are problems with the above inspection items, do not install the device and contact your distributor first. If the problem persists, contact SUNGROW in time.

## 1.2 Installation Safety

**⚠ DANGER**

- Make sure there is no electrical connection before installation.
- Before drilling, avoid the water and electricity wiring in the wall.

**⚠ CAUTION**

Improper installation may cause personal injury!

- If the product supports hoisting transport and is hoisted by hoisting tools, no one is allowed to stay under the product.
- When moving the product, be aware of the product weight and keep the balance to prevent it from tilting or falling.

**NOTICE**

Before operating the product, must check and ensure that tools to be used have been maintained regularly.

## 1.3 Electrical Connection Safety

**⚠ DANGER**

- Before electrical connections, please make sure that the inverter is not damaged, otherwise it may cause danger!
- Before electrical connections, please make sure that the inverter switch and all switches connected to the inverter are set to "OFF", otherwise electric shock may occur!

**⚠ DANGER**

The PV string will generate lethal high voltage when exposed to sunlight.

- Operators must wear proper personal protective equipment during electrical connections.
- Must ensure that cables are voltage-free with a measuring instrument before touching DC cables.
- Respect all safety instructions listed in relevant documents about PV strings.
- The inverter must not be connected to a PV string that requires positive or negative grounding.

**⚠ DANGER**

Danger to life due to a high voltage inside the inverter!

- Be sure to use special insulation tools during cable connections.
- Note and observe the warning labels on the product, and perform operations strictly following the safety instructions.
- Respect all safety instructions listed in this manual and other pertinent documents.

**⚠ WARNING**

Damage to the product caused by incorrect wiring is not covered by the warranty.

- Electrical connection must be performed by professionals.
- All cables used in the PV generation system must be firmly attached, properly insulated, and adequately dimensioned.

**⚠ WARNING**

- Check the positive and negative polarity of the PV strings, and connect the PV connectors to corresponding terminals only after ensuring polarity correctness.
- During the installation and operation of the inverter, please ensure that the positive or negative poles of PV strings do not short-circuit to the ground. Otherwise, an AC or DC short-circuit may occur, resulting in equipment damage. The damage caused by this is not covered by the warranty.
- Do not connect any load between the inverter and the AC circuit breaker directly connected to it, so as to prevent the switch from tripping by mistake.
- Determine the specifications of AC circuit breakers strictly in compliance with the applicable local laws and regulations and safety standards or the recommendation by SUNGROW. Otherwise, the switch may not open in time in the event of something abnormal, which may then lead to safety incidents.

**NOTICE**

Comply with the safety instructions related to PV strings and the regulations related to the local grid.

## 1.4 Operation Safety

**⚠ DANGER**

When routing cables, ensure a distance of at least 30 mm between the cables and heat-generating components or areas to protect the insulation layer of cables from aging and damage.

When the product is working:

- Do not touch the product enclosure.
- It is strictly forbidden to plug and unplug any connector on the inverter.
- Do not touch any wiring terminal of the inverter. Otherwise, electric shock may occur.
- Do not disassemble any parts of the inverter. Otherwise, electric shock may occur.
- It is strictly forbidden to touch any hot parts of the inverter (such as the heat sink). Otherwise, it may cause burns.
- Do not connect or remove any battery. Otherwise, electric shock may occur.
- Do not connect or remove any PV string or any PV module in a string. Otherwise, electric shock may occur.
- If the inverter is equipped with a DC switch, do not operate it. Otherwise, it may cause device damage or personal injury.

Do not take other actions, such as setting parameters or cutting off power, during the process of inverter firmware update, to avoid update failure.

## 1.5 Maintenance Safety

### DANGER

**Risk of inverter damage or personal injury due to incorrect service!**

- Before maintenance, disconnect the AC circuit breaker on the grid side and then the DC switch. If a fault that may cause personal injury or device damage is found before maintenance, disconnect the AC circuit breaker and wait until the night before operating the DC switch. Otherwise, a fire inside the product or an explosion may occur, causing personal injuries.
- After the inverter is powered off for 10 minutes, measure the voltage and current with professional instrument. Only when there is no voltage nor current can operators who wear protective equipment operate and maintain the inverter.
- Even if the inverter is shut down, it may still be hot and cause burns. Wear protective gloves before operating the inverter after it cools down.

### DANGER

**Touching the power grid or the contact points and terminals on the inverter connected to the power grid may lead to electric shock!**

- The power grid side may generate voltage. Always use a standard voltmeter to ensure that there is no voltage before touching.

### CAUTION

**To prevent misuse or accidents caused by unrelated personnel, post prominent warning signs or demarcate safety warning areas around the product.**

### NOTICE

**To avoid the risk of electric shock, do not perform any other maintenance operations beyond those described in this manual. If necessary, contact your distributor first. If the problem persists, contact SUNGROW. Otherwise, the losses caused is not covered by the warranty.**

**NOTICE**

- If the paint on the inverter enclosure falls or rusts, repair it in time. Otherwise, the inverter performance may be affected.
- Do not use cleaning agents to clean the inverter. Otherwise, the inverter may be damaged, and the loss caused is not covered by the warranty.
- As the inverter contains no parts that can be maintained, never open the enclosure of the inverter or replace any internal components without authorization. Otherwise, the loss caused is not covered by the warranty.
- Do not open the maintenance door in rainy or snowy weather. If it is inevitable, take proper protective measures to avoid the ingress of rainwater and snow into the maintenance compartment; otherwise, the product's operation may be affected.
- Before closing the maintenance door, check whether there is any object left inside the maintenance compartment, such as screws, tools, etc.
- It is recommended for users to use cable sheathing to protect the AC cable. If the cable sheathing is used, make sure it is positioned inside the maintenance compartment.

## 1.6 Disposal Safety

** WARNING**

Please scrap the product in accordance with relevant local regulations and standards to avoid property losses or casualties.

## 2 Product Description

### 2.1 System Introduction

The inverter is a transformerless 3-phase PV grid-connected inverter. As an integral component in the PV power system, the inverter is designed to convert the direct current power generated from the PV modules into grid-compatible AC current and feeds the AC current to the utility grid.

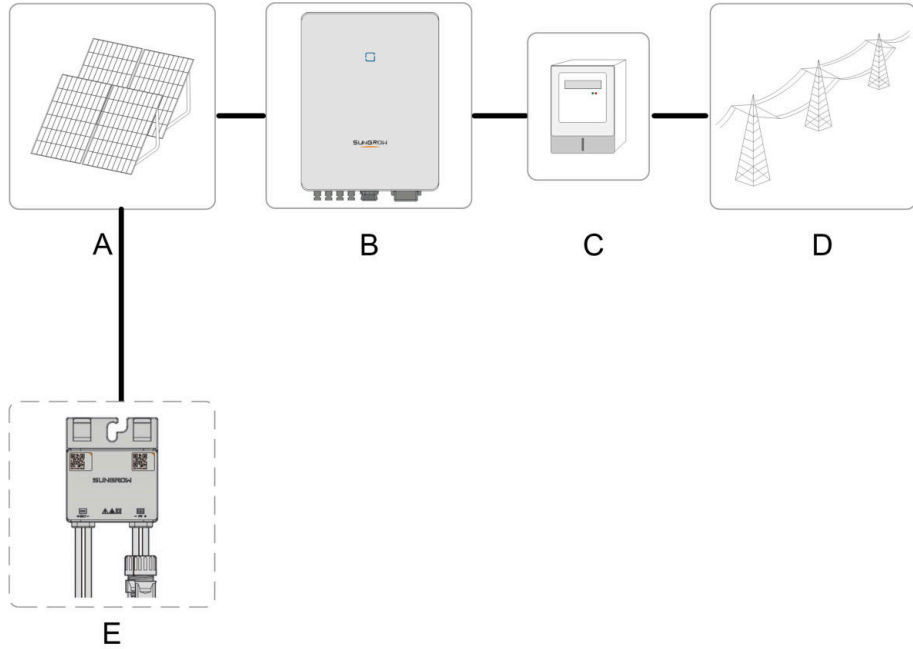
#### **⚠ WARNING**

- **The inverter must only be operated with PV strings with class II protection in accordance with IEC 61730, application class A. It is not allowed for the positive pole or the negative pole of the PV strings to be grounded. This can cause damage to the inverter.**
- **Do not connect any local load between the inverter and the AC circuit breaker.**

#### **NOTICE**

**The inverter applies only to the scenarios described in this manual.**

The intended usage of the inverter is illustrated in the following figure (what are in the dashed box are optional).



**Figure 2-1** Inverter Application in PV Power System

Item	Description	Note
A	PV strings	Compatible with monocrystalline silicon, polycrystalline silicon, and thin-film modules without grounding
B	Inverter	SG3.0RT, SG4.0RT, SG5.0RT, SG6.0RT, SG7.0RT, SG8.0RT, SG10RT, SG12RT, SG15RT, SG17RT, SG20RT, SG5.0RT-P2, SG6.0RT-P2, SG7.0RT-P2, SG8.0RT-P2, SG10RT-P2, SG12RT-P2, SG15RT-P2, SG17RT-P2, SG20RT-P2
C	Metering device	Meter cupboard with power distribution system
D	Utility grid	TT, TN-C, TN-S, TN-C-S, IT
E	Optimizer	Inverters that are compatible with the optimizer include: SG5.0RT-P2, SG6.0RT-P2, SG7.0RT-P2, SG8.0RT-P2, SG10RT-P2, SG12RT-P2, SG15RT-P2, SG17RT-P2, SG20RT-P2. SG3.0–20RT models are not compatible with the optimizer

Please refer to the optimizer user manual for details.

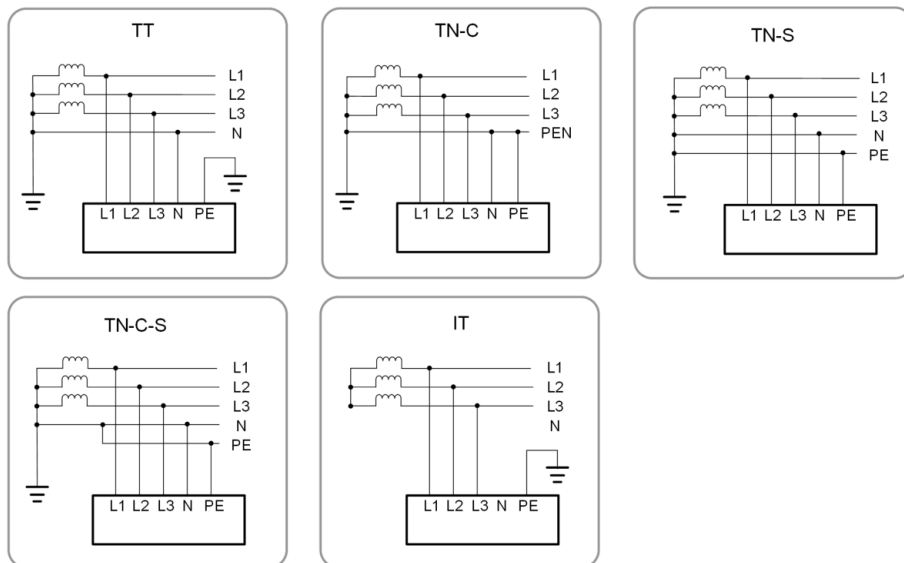


Please contact your local sales staff to confirm that the optimizer is available for sale in your territory. SP600S optimizer is not compatible with third-party products.

**NOTICE**

**It is recommended to use the optimizer produced by SUNGROW. Optimizers from third-party manufacturers may fail or even cause unknown losses.**

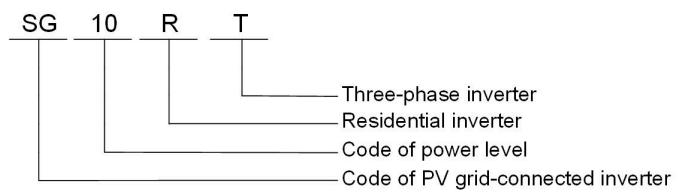
The following figure shows the common grid configurations.



**2.2 Product Introduction**

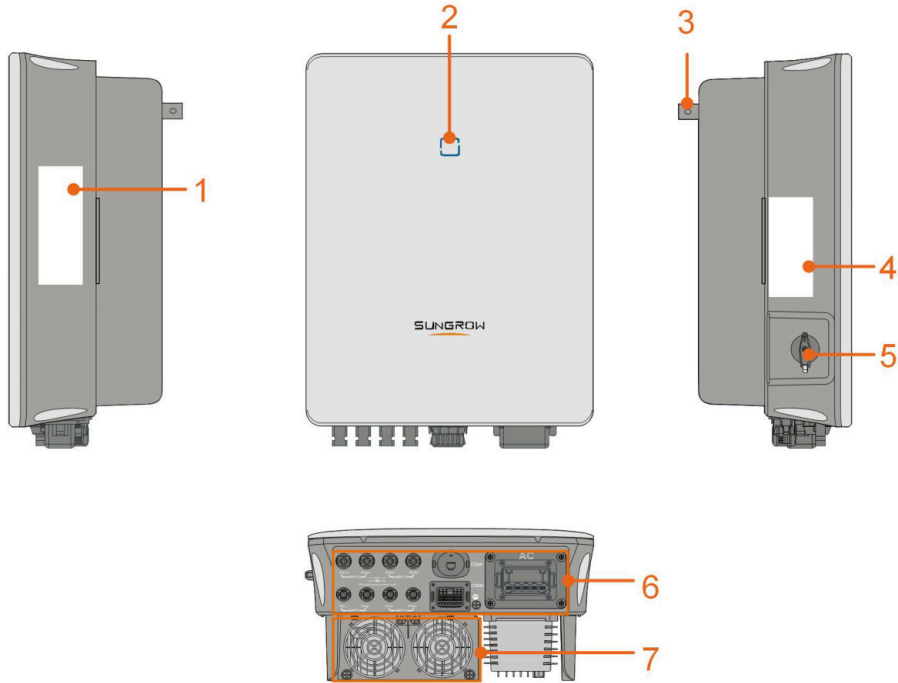
**Model Description**

The model description is as follows (take SG10RT as an example):



## Appearance

The following figure shows the appearance of the inverter. The image shown here is for reference only. The actual product received may differ.



**Figure 2-2** Inverter Appearance

No.	Name	Description
1	Nameplate	To clearly identify the product, including device model, S/N, important specifications, marks of certification institutions, etc.
2	LED indicator	To indicate the current working state of the inverter.
3	Hanger	Complement to the included wall-mounting bracket for hanging the inverter.
4	Label	Information about <b>COM2</b> pin definition, supported DRM modes, etc.
5	DC switch(Optional )	To safely disconnect the DC circuit whenever necessary.
6	Electrical connection area	DC terminals (SG20RT for example), AC terminal, additional grounding terminal and communication terminals.

No.	Name	Description
7	Fans	Optimization of the inverter's heat dissipation. Only the SG15RT, SG17RT, SG20RT, SG15RT-P2, SG17RT-P2 and SG20RT-P2 are equipped with fans.

### Dimensions

The following figure shows the dimensions of the inverter.

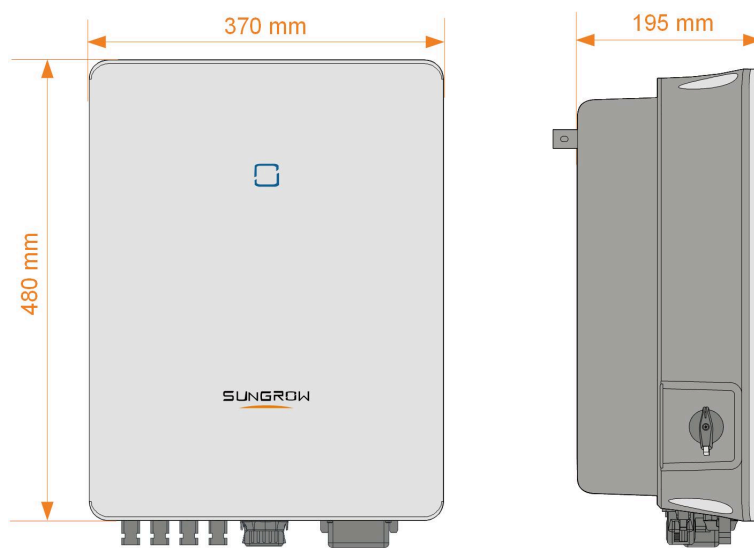













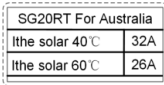


Figure 2-3 Dimensions of the Inverter(in mm)

### 2.3 Symbols on Product

Symbol	Explanation
	Regulatory compliance mark.
	TÜV mark of conformity.
	CE mark of conformity. EU/EEA Importer.
	UKCA mark of conformity.
	CMIM mark of conformity.

Symbol	Explanation
	Do not dispose of the inverter together with household waste.
	The inverter does not have a transformer.
	Disconnect the inverter from all the external power sources before maintenance!
	Read the user manual before maintenance!
	Burn danger due to the hot surface that may exceed 60°C.
	Danger to life due to high voltages! Only qualified personnel can open and service the inverter.
	Danger to life due to high voltages! Do not touch live parts for 10 minutes after disconnection from the power sources.
	External protective grounding terminal.
	Conventional enclosed thermal current with solar effects for PV Input Switch. <sup>(1)</sup>


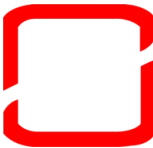

(1)For Australia. The data is based on actual measurement of the SG20RT and is applicable to other models in the series.

- The table shown here is for reference only. The actual product received may differ.
- Users may also attach other warning signs as per the requirements of the local standards or installation specifications.

## 2.4 LED Indicator

The LED indicator on the front of the inverter indicates the working state of the inverter.

**Table 2-1** LED Indicator State Description

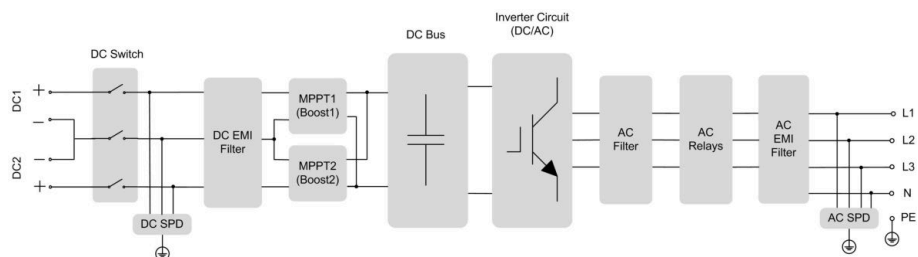
LED Color	State	Definition
 Blue	On	The inverter is operating normally.
	Blink	The inverter is at standby or startup state (not feeding power into the grid).
 Red	On	A system fault has occurred.
 Gray	Off	Both the AC and DC sides are powered down.

### **⚠ WARNING**

**Voltage may still be present in AC side circuits after the indicator is off. Pay attention to the electricity safety when operating.**

## 2.5 Circuit Diagram

The following figure shows the main circuit of the inverter.



**Figure 2-4** Circuit Diagram (SG5.0RT for example)

- DC Switches can safely disconnect the PV input when necessary to ensure the safe operation of the inverter and the safety of personnel.
- The DC SPD provides a discharge circuit for the DC side overvoltage to prevent it from damaging the internal circuits of the inverter.

- EMI filters can filter out the electromagnetic interference inside the inverter to ensure that the inverter meets the requirements of electromagnetic compatibility standards.
- The MPPT is used to ensure a maximum power from PV arrays at different PV input conditions.
- The Inverter Circuit converts the DC power into grid-compliant AC power and feeds it into the grid.
- The AC filter filters the output AC component of high frequency to ensure that the output current meets the grid requirements.
- The AC relay isolates the AC output of the inverter from the grid, making the inverter safe from the grid in case of inverter failure or grid failure.
- The AC SPD provides a discharge circuit for the AC side overvoltage to prevent it from damaging the internal circuits of the inverter.

### **⚠ DANGER**

**If the lightning level exceeds the protection level of the product, surge protection and overvoltage protection may fail, resulting in electric shock and fatal injury!**

## 2.6 Function Description

### Basic Function

- Conversion function  
The inverter converts the DC power from the PV array to the AC power, in conformity with the grid requirements.
- Data storage  
The inverter logs running information, error records, etc.
- Parameter configuration  
The inverter provides various parameter configurations for optimal operation. Parameters can be set via the iSolarCloud App or the cloud server.
- Communication interface  
The inverter is equipped with two communication interfaces. The communication device can be connected to the inverter via both interfaces.  
After communication connection is established, users can view inverter information, operational data and can set inverter parameters through the iSolarCloud.

It is recommended to use the communication module from SUNGROW. Using a device from other companies may lead to communication failure or other unexpected damage.

- Protection Function  
Several protective functions are integrated in the inverter, including short circuit protection, grounding insulation resistance monitoring, residual current protection, grid monitoring, DC overvoltage/overcurrent protection, etc.

### Earth Fault Alarm

The inverter is equipped with a DO relay for the local earth fault alarm. The additional equipment required is a light indicator and/or a buzzer that needs additional power supply.

After the connection, if the earth fault occurs, the DO dry-contact will switch on automatically to signal the external alarm.

### DRM ("AU"/"NZ")

The DRM function is only applicable to a single inverter.

The inverter provides terminals for connecting to a Demand Response Enabling Device (DRED). After the connection, the DRED asserts demand response modes (DRMs). The inverter detects and initiates a response to all supported demand response modes listed in the following table.

**Table 2-2** Demand Response Mode Explanation

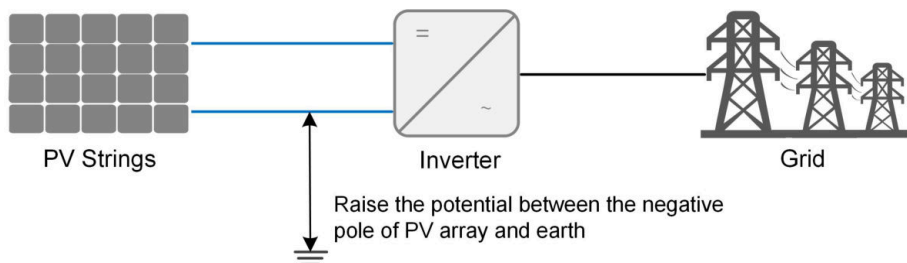
Mode	Explanation
DRM0	The inverter is in the state of shutdown.

### Ripple Control

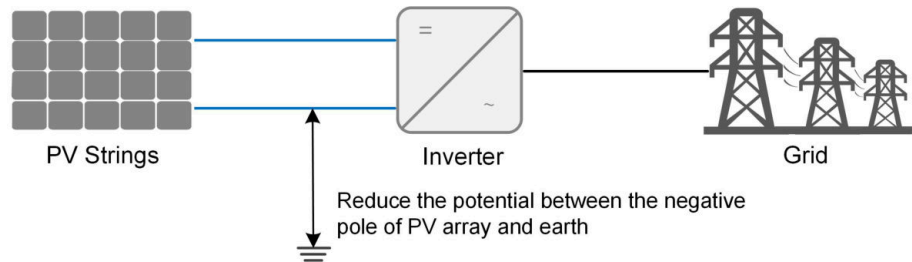
The inverter provides terminals (DRM) for connecting to a Ripple Control Receiver (RCR). After the connection, the grid dispatching center issues regulation instructions via dry contact (DI). The inverter can control power output according to the local preset instructions.

### PID Recovery

- For positive voltage scheme, after the PID function is enabled, the voltage to ground of all PV strings is greater than 0, and therefore the PV string-to-ground voltage is a positive value.



- For negative voltage scheme, after the PID function is enabled, the voltage to ground of all PV strings is lower than 0, and therefore the PV string-to-ground voltage is a negative value.



## NOTICE

- **Before enabling the PID recovery function, make sure the voltage polarity of the PV modules to ground meets requirement. If there are any questions, contact the PV module manufacturer or read its corresponding user manual.**
- **If the voltage scheme for the PID recovery function does not meet the requirement of corresponding PV modules, the PID function will not work as expected or even damage the PV modules.**

When the inverter is not running, the PID module will apply inverse voltage to PV modules, to restore the degraded modules.

- If the PID recovery function is enabled, it only works at night.
- After the PID recovery function is enabled, the voltage of the PV strings to ground is 500 V DC by default, and the default value can be modified through the App.

### Auto-test (for Italy CEI0-21 Grid Code Only)

The Italy CEI0-21 grid code requires auto-test for the inverter before grid connection. During the auto-test, the inverter checks the protection threshold and protection time of the 1-level overvoltage (59.S1), 2-level overvoltage (59.S2), 1-level undervoltage (27.S1), 2-level undervoltage (27.S2), 1-level overfrequency (81>.S1), 2-level overfrequency (81>.S2), 1-level underfrequency (81<.S1), 2-level underfrequency (81<.S2) to ensure that the inverter could meet the requirements of CEI0-21 to protect the grid from abnormality after the inverter is operational.

### AFCI Function (Optional)

- **AFCI activation**  
This function can be enabled to detect whether serial fault arc occurs in the loop between PV array and inverter.
- **AFCI self-test**  
This function is intended to test whether AFCI works as normal.
- **Clear AFCI Alarm**  
When the inverter detects the AFCI alarm, it stops working. Clear the AFCI alarm so that the inverter can restart the detection.
- **Protection Coverage**

Two types of classifications are defined for AFCI protection, "F (Full coverage)" and "P (Partial coverage)". Full coverage protection ("F") is available for this inverter.

- AFPE

This inverter is equipped with a fully integrated AFPE, which is implemented within the inverter connected to the PV array and makes use of the enclosure and terminals of the inverter.

- Method of Implementation

Two implementation options are available for AFCI protection, "D" and "I". "D" represents "Distributed detection system", where the AFPE comprises more than one device. The devices may be standalone devices or partially integrated within the power conversion equipment (PCE). While "I" represents "PCE integrated device", where the AFPE is implemented within a PCE connected to the PV array and makes use of the enclosure and terminals of the PCE. "I" is adopted for this inverter.

- Reconnection Method

Three reconnection methods are available for this inverter:

1. Manual reconnection

Reconnection can only be performed manually after arc interruption. You can log in via local access to the iSolarCloud App, and choose **More**→ **Settings**→ **Operation Parameters**→ **AFCI Parameters**→ **Clear AFCI Alarm**; after clearing the fault alarm, restart the device.

2. Remote manual reconnection

Reconnection can be performed via remote access to the AFPE after interruption. You can log in to iSolarCloud remotely. Then, find the target plant and choose **Settings**; select the device, and choose **Advanced Settings**→ **Power Control**→ **Clear AFCI Alarm**. After clearing the fault alarm, restart the device.

3. Automatic reconnection

Reconnection can be performed automatically after arc interruption.

Rule: Upon detecting a real arc fault, the device will report a fault and shut down. Within the day, for the 1st to 4th arc fault alarm, the device will shut down for 10 minutes, then the alarm will be cleared and the device will restart; when the 5th or more arc fault is reported, the device will shut down and not resume operation on that day.

In the event of the 1st to 4th arc fault alarm, ARM is powered off and restarted, and the device can restart and reconnect to the grid normally, with the fault count reset to "0". When the 5th arc fault is detected, if ARM is powered off and restarted due to external environment factors, the device will report a fault and shut down, with the fault count changing to "1"; after 10 minutes, the fault alarm will be cleared and the device will restart. If ARM is not powered off when the 5th or more arc fault is reported, you need to clear the fault manually to get the device restarted and reconnected to the grid normally; in this case, the fault count will be reset to "0". Or you can wait for the fault to be cleared automatically the next day, in which case the fault count will change to "1". See "Manual reconnection" and "Remote manual reconnection" for instructions on how to clear the fault alarm manually.

- AFCI protection configuration.

The AFCE configuration of each inverter model is shown in the table below.

Model	SG15/1 7/20RT	SG15/1 7/20RT -P2	SG7.0/ 8.0/10/1 2RT	SG7.0/ 8.0/10/ 12RT- P2	SG5.0/ 6.0RT	SG5.0/ 6.0RT- P2
Classification	F-I-AFPE-1-2/2-2		F-I-AFPE-1-2/1-2		F-I-AFPE-1-1/1-2	
Number of monitored strings per input port	1					
Number of input ports per channel	2/2		2/1		1	
Number of monitored channels	2		2		2	
Rated channel current	25/25	32/32	25/12.5	32/16	12.5/12.5	16/16
Maximum current per input port	12.5	16	12.5	16	12.5	16
Rated interruption current	12.5	16	12.5	16	12.5	16

The fault arc detection function meets the standard requirements, please test under the working conditions as required by the standard.

### SPI Function(for Italy CEI0-21 Grid Code Only)

The inverter SPI interface, only for Italy, is able to easily choose the grid protection mode based on the local plant requirements:

- Local SPI Mode: protected by the preset values in inverter.
- External SPI Mode: protected by a separate SPI protection device on site.

Plant Size	≤ 11.08 kVA		> 11.08 kVA		
	SPI Control Modes	Local SPI Mode (Default in Inverter)		Local SPI Mode (Default in Inverter)	
SPI Interface	Integrated in Inverter		Integrated in Inverter		Separate SPI Protection Device on Site
External SPI Signal Setting	0	0	0	0	1
Local SPI Signal Setting	0 (Default in Inverter)	1	0 (Default in Inverter)	1	1
59.S1	253 V / ≤ 603 s	253 V / ≤ 603 s	253 V / ≤ 603 s	253 V / ≤ 603 s	253 V / ≤ 603 s
59.S2	264.5 V / 0.2 s	264.5 V / 0.2 s	264.5 V / 0.2 s	264.5 V / 0.2 s	264.5 V / ≤ 4 s
27.S1	195.5 V / 1.5 s	195.5 V / 1.5 s	195.5 V / 1.5 s	195.5 V / 1.5 s	195.5 V / ≤ 4 s
27.S2	34.5 V / 0.2 s	34.5 V / 0.2 s	34.5 V / 0.2 s	34.5 V / 0.2 s	34.5 V / ≤ 4 s
81>.S1	—	50.2 Hz / 0.1 s	—	50.2 Hz / 0.1 s	51.5 Hz / ≤ 4 s
81<.S1	—	49.8 Hz / 0.1 s	—	49.8 Hz / 0.1 s	47.5 Hz / ≤ 4 s
81>.S2	51.5 Hz / 0.1 s	51.5 Hz / 0.1 s	51.5 Hz / 0.1 s	51.5 Hz / 0.1 s	51.5 Hz / ≤ 4 s

Plant Size	≤ 11.08 kVA		> 11.08 kVA		
	81<.S 2	47.5 Hz / 0.1 s	47.5 Hz / 0.1 s	51.5 Hz / 0.1 s	51.5 Hz / 0.1 s
Notes	—	—	—	—	Values from SPI Protection Device on site shall not exceed the above

### Optimizer Functions

- Module-level MPPT  
Increase the power generation of the PV system by continuously tracking the maximum power point of the PV module.
- Module-level shutdown  
Quickly reduce module voltage.
- Module-level monitoring  
The optimizer can monitor the performance of modules.
- Module-level IV curve diagnosis  
The optimizer can scan the module IV curve and judge whether a module fault occurs.

## 3 Unpacking and Storage

### 3.1 Unpacking and Inspection

The product is thoroughly tested and strictly inspected before delivery. Nonetheless, damage may still occur during shipping. For this reason, please conduct a thorough inspection after receiving the product.

- Check the packing case for any visible damage.
- Check the scope of delivery for completeness according to the packing list.
- Check the inner contents for damage after unpacking.

Contact SUNGROW or the transport company in case of any damage or incompleteness, and provide photos to facilitate services.

Do not dispose of the original packing case. It is recommended to store the device in the original packing case when the product is decommissioned.

#### NOTICE

- **After receiving the product, check whether the appearance and structural parts of the device are damaged, and check whether the packing list is consistent with the actual ordered product. If there are problems with the above inspection items, do not install the device and contact your distributor first. If the problem persists, contact SUNGROW in time.**
- **If any tool is used for unpacking, be careful not to damage the product.**

### 3.2 Inverter Storage

Proper storage is required if the inverter is not installed immediately.

- Store the inverter in the original packing case with the desiccant inside.
- The storage temperature must be always between  $-30^{\circ}\text{C}$  and  $+70^{\circ}\text{C}$ , and the storage relative humidity must be always between 0 and 95 %, non-condensing.
- In case of stacking storage, the number of stacking layers should never exceed the limit marked on the outer side of the packing case.
- The packing case should be upright.
- If the inverter needs to be transported again, pack it strictly before loading and transporting it.

- Do not store the inverter in places susceptible to direct sunlight, rain, and strong electric field.
- Do not place the inverter in places with items that may affect or damage the inverter.
- Store the inverter in a clean and dry place to prevent dust and water vapor from eroding.
- Do not store the inverter in places with corrosive substances or susceptible to rodents and insects.
- Carry out periodic inspections. Inspection shall be conducted at least once every six months. If any insect or rodent bites are found, replace the packaging materials in time.
- If the inverter has been stored for one year or longer, or has been mounted but remains non-operational for more than three months, it must be inspected and tested by qualified personnel before being put into operation.

**NOTICE**

**Please store the inverter according to the storage requirements. Product damage caused by failure to meet the storage requirements is not covered by the warranty.**

## 4 Mechanical Mounting

### WARNING

Respect all local standards and requirements during mechanical installation.

### 4.1 Safety During Mounting

#### DANGER

Make sure there is no electrical connection before installation.  
Before drilling, avoid the water and electricity wiring in the wall.

#### WARNING

For specific requirements for the installation environment, see [4.2.1 Installation Environment Requirements](#). In case the environment where the product is installed does not meet the requirements, SUNGROW shall not be held liable for any property damage arising therefrom.

#### CAUTION

Improper handling may cause personal injury!

- When moving the product, be aware of its weight and keep the balance to prevent it from tilting or falling.
- Wear proper protective equipment before performing operations on the product.
- The bottom terminals and interfaces of the product cannot directly contact the ground or other supports. The product cannot be directly placed on the ground.

#### NOTICE

During installation, ensure that no device in the system causes it hard for the DC switch and the AC circuit breaker to act or hinders maintenance personnel from operating.

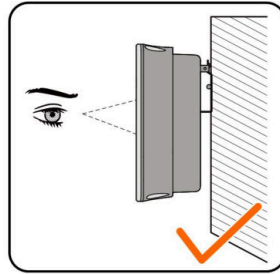
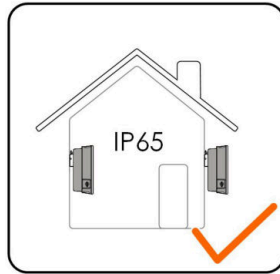
If drilling is required during installation:

- Wear goggles and protective gloves when drilling holes.
- Make sure to avoid the water and electricity wiring in the wall before drilling.
- Protect the product from shavings and dust.

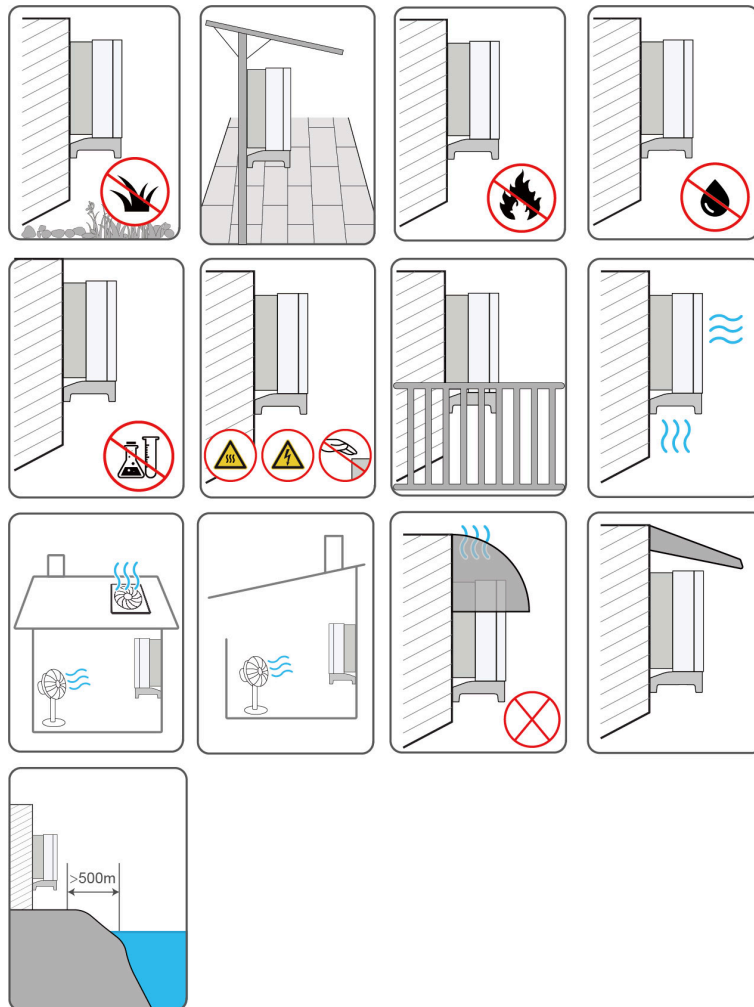
## 4.2 Location Requirements

To a large extent, a proper installation location ensures safe operation, service life, and performance of the inverter.

- The inverter with protection rating IP65 can be installed both indoors and outdoors.
- The inverter should be installed at a height that allows easy viewing of the LED indicator panel, as well as easy electrical connection, operation and maintenance.



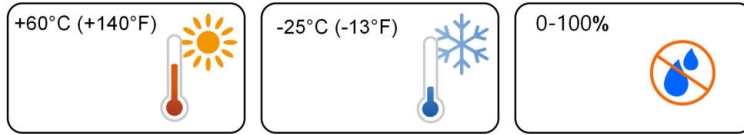
### 4.2.1 Installation Environment Requirements



- If the inverter is installed in a place with lush vegetation, weed on a regular basis. In addition, the ground beneath the inverter needs to undergo certain treatment, such as laying cement or gravel, etc. (an area of 3 m × 2.5 m is recommended).
- Do not install the inverter in an environment with flammables, explosives, or smoke.
- Do not install the inverter in places prone to water leak, e.g., under the air-conditioner vent, the air vent, or the cable outlet window of the machine room, so as to prevent device damage or short circuit caused by intrusion of water.
- Do not install the inverter in a place with corrosives such as corrosive gas and organic solvent, etc.
- When the inverter is running, its surface may carry high voltages or get very hot. Do not touch it; otherwise, it may lead to burns or electric shocks.
- Do not install the inverter in a place that can be easily reached.
- The installation site must have solid ground, free of rubber-like soils (which cannot be effectively compacted) or weak soils, and should not be prone to subsidence. Also,

avoid low-lying areas where water or snow may accumulate. Ensure the site is located above the highest recorded water level in the area.

- Do not install the inverter in a position that could be flooded.
- To prevent vegetation or water on the ground from impacting inverter operation, if the space above meets the designated requirements, elevate the inverter to an appropriate height.
- Install the inverter in a place with shelter, so as to prevent it from getting impacted by direct sunlight and severe weather (e.g., snow, rain, and lightning). The inverter will derate in high temperatures for self-protection. If installed in a place directly exposed to sunlight, as the temperature rises, the inverter may experience power reduction.
- Good heat dissipation is very important to the inverter. Please install the inverter in a ventilated environment.
- If the inverter needs to be installed in a closed or semi-closed environment, please install additional heat dissipation or ventilation devices. Furthermore, while the inverter is operating, ensure the indoor ambient temperature does not exceed the outdoor ambient temperature. A semi-closed environment refers to a special space where natural ventilation is limited and gas or heat may easily accumulate, although it is not fully enclosed on all six sides.
- Please consult SUNGROW before installing inverters outdoors in areas prone to salt damage, which are mainly coastal areas within 500 meters of the coast. The sedimentation amount of salt spray is correlated to the characteristics of the seawater, sea winds, precipitation, air humidity, topography, and forest coverage in the adjacent sea areas, and there are substantial differences between different coastal areas.
- To ensure device safety and service life, avoid using this product in highly polluted environments containing substances such as sulfur or halogens.
- The inverter is strictly prohibited from being installed in environments with vibration or strong electromagnetic fields (including strong common-mode interference). A strong magnetic field environment refers to one where the magnetic field strength exceeds 30 A/m. The aforementioned environments may cause the product to malfunction.
- In dusty environments such as places full of dust, smoke, or floc, particles may cling to the device's air outlet or heat sink, thus impacting its heat dissipation performance or even getting it damaged. Therefore, do not install the inverter in dusty environments. If the inverter has to be installed in such environments, please clean its fans and heat sink on a regular basis to ensure a good heat dissipation performance.
- To avoid disturbing residents in living areas with noise generated during the operation of the device, do not install the inverter in noise-sensitive areas such as bedrooms. It is preferable to choose an open location that is far away from the living and resting areas.
- The average temperature approximately 1 m around the inverter should be taken as its ambient operating temperature. The temperature and humidity should meet the requirements below:



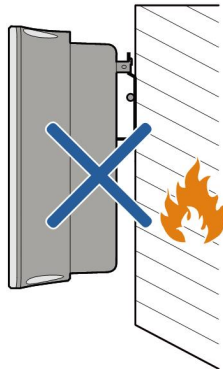
#### 4.2.2 Carrier Requirements

The mounting structure where the inverter is installed must comply with local/national standards and guidelines. Ensure that the installation surface is solid enough to bear four times the weight of the inverter and is suitable for the dimensions of the inverter (e.g. cement walls, plasterboard walls, etc.).

Do not install the inverter on a carrier that may vibrate in resonance, so as to avoid making bigger noise.

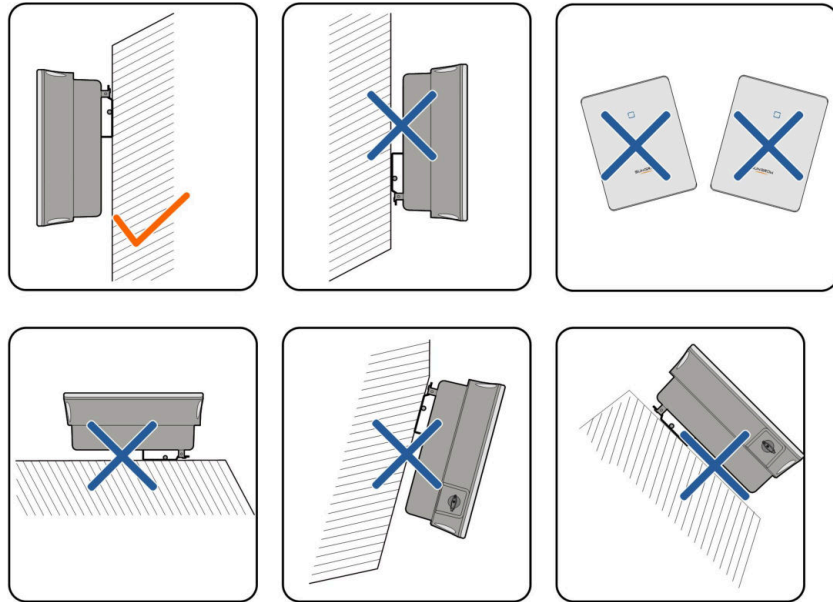
Installation on combustible building materials is strictly prohibited. Suitable mounting surfaces include:

Non-combustible wall surfaces: Concrete, fire-resistant gypsum board, brick wall, etc. Non-combustible roof structures: Color-Coated corrugated steel roofing sheets, precast concrete slabs, fiber-reinforced cement boards, etc.



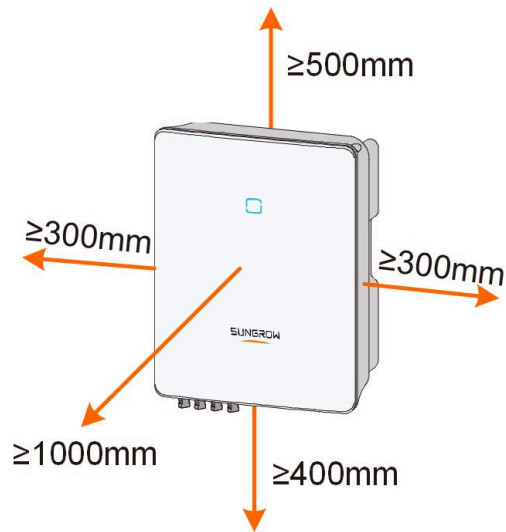
#### 4.2.3 Angle Requirements

Install the inverter vertically. Never install the inverter horizontally, or at forward/backward tilted, side tilted, or upside down.

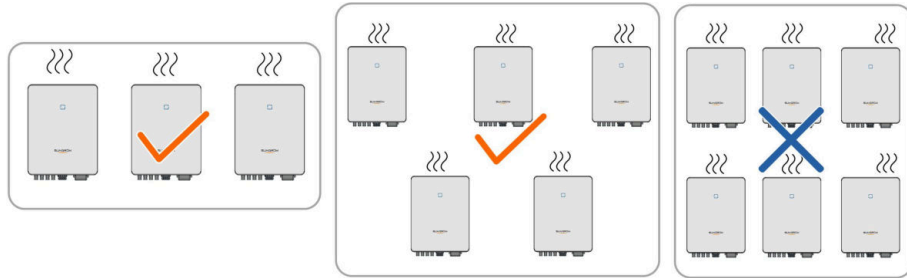


#### 4.2.4 Clearance Requirements

Reserve enough clearance around the inverter to ensure sufficient space for heat dissipation.



In case of multiple inverters, reserve specific clearance between the inverters.

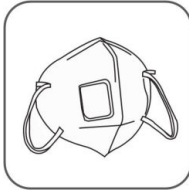


Install the inverter at an appropriate height for ease of viewing LED indicator and operating switch(es).

### 4.3 Installation Tools

Installation tools include but are not limited to the following recommended ones. If necessary, use other auxiliary tools on site.

**Table 4-1** Tool specification

			
Goggles	Earplugs	Dust mask	Safety gloves
			
Safety shoes	Utility knife	Marker	Anti-static wrist strap
			
Wire cutter	Wire stripper	Hydraulic pliers	Rubber mallet



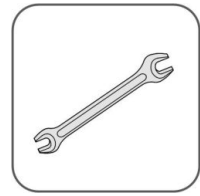
Hammer drill  
( $\phi 10$ )



Phillips  
screwdriver (M3,  
M4, M6)



Electric  
screwdriver (M3,  
M4, M6)



Open-end wrench  
(30 mm, 35 mm,  
46 mm)



RJ45 crimping  
tool



Vacuum cleaner



Measuring tape



Heat shrink tubing



Heat gun



OT terminal  
crimping tool (4  
 $\text{mm}^2$ –6  $\text{mm}^2$ )



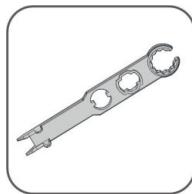
MC4 terminal  
crimping tool (0.5  
 $\text{mm}^2$ –1.0  $\text{mm}^2$ )



Multimeter ( $\geq 1100$   
Vdc)



Slotted  
screwdriver (M2)



Connector wrench

## 4.4 Moving the Inverter

Before installation, remove the inverter from the packing case and move it to the installation site. Follow the instructions below as you move the inverter:

- Always be aware of the weight of the inverter.
- Lift the inverter using the handles positioned on both sides of the inverter.
- Move the inverter by one or two people or by using a proper transport tool.
- Do not release the equipment unless it has been firmly secured.

### **⚠ CAUTION**

**Improper handling may cause personal injury!**

- **Arrange an appropriate number of personnel to carry the inverter according to its weight, and installation personnel should wear protective equipment such as anti-impact shoes and gloves.**
- **Attention must be paid to the center of gravity of the inverter to avoid tilting during handling.**
- **Placing the inverter directly on a hard ground may cause damage to its metal enclosure. Protective materials such as sponge pad or foam cushion should be placed underneath the inverter.**
- **Move the inverter by holding the handles on it. Do not move the inverter by holding the terminals.**

## 4.5 Installing the Inverter

Inverter is installed on the wall by means of wall-mounting bracket and the expansion plug sets.

The expansion plug set shown below is recommended for the installation.



(1) Self-tapping  
screw M6

(2) Expansion  
tube

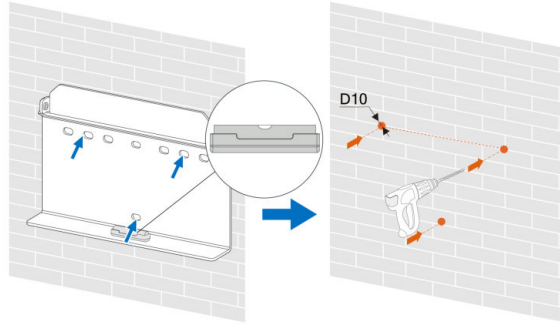
(3) Fender washer

(4) Spring washer

**Step 1** Place the wall-mounting bracket to a proper position on the wall. Observe the level on the bracket and adjust until the bubble is in the middle position. Mark the positions and drill the holes.

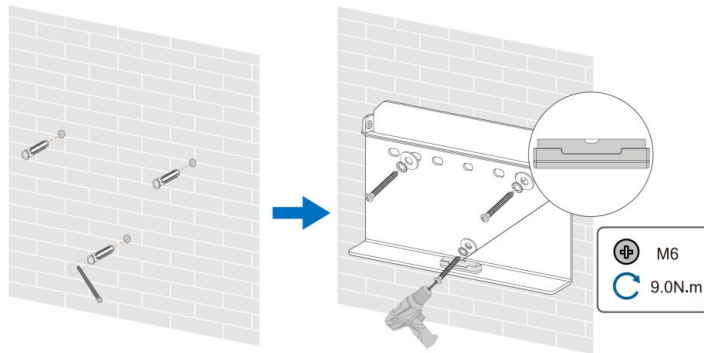
### **NOTICE**

**The depth of the holes should be about 70 mm.**

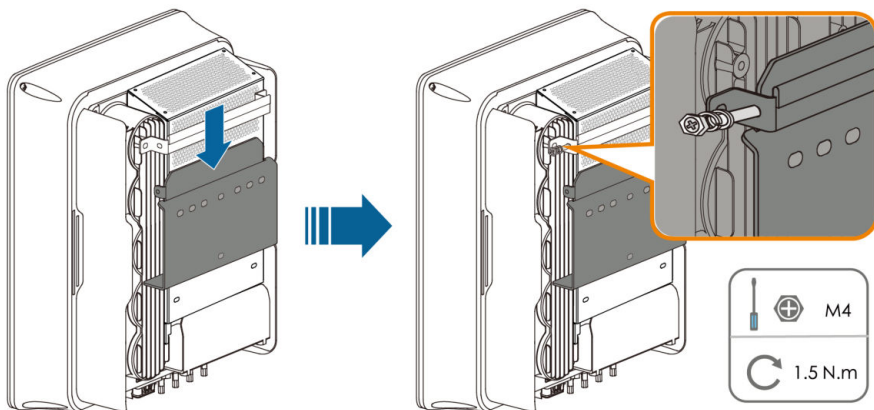


\* The image shown here is for reference only. The actual product received may differ.

**Step 2** Place the expansion tubes into the holes. Then secure the wall-mounting bracket to the wall firmly with the expansion bolt sets.



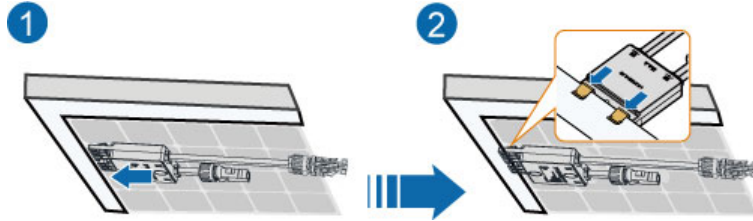
**Step 3** Lift the inverter and slide it down along the wall-mounting bracket to make sure they match perfectly. Use the fastener set to lock the device.



--End

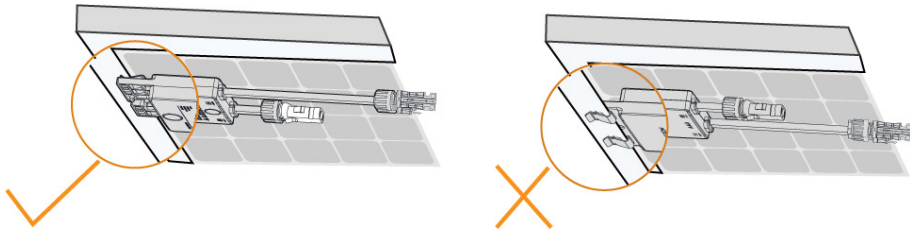
## 4.6 Installing Optimizer(Optional)

**Step 1** As shown in the figure below, clamp the optimizer parallel to the back of the PV module by clips.

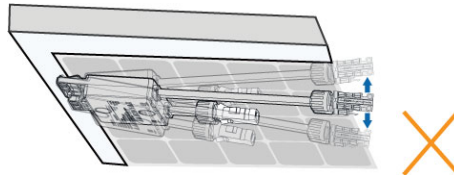


### NOTICE

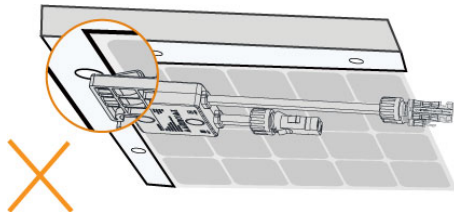
- Optimizer is only sold in certain countries and regions. For details, please consult your local company's sales.
- Please ensure that the optimizer is installed facing the back of the module. Otherwise, the clip may get damaged.



- Do not forcibly bend the clips when installing the optimizer by clips. Otherwise, the clip may be damaged.



- Do not clamp the optimizer into holes in the module frame during installation. Otherwise, the optimizer cannot be removed or the clips may be damaged.



- It is recommended to install optimizers on the same side of modules.
- Do not clamp and remove the optimizer multiple times. Otherwise, the clip may become loose, affecting normal use.

--End

# 5 Electrical Connection

## 5.1 Safety Instructions

### DANGER

The PV string will generate lethal high voltage when exposed to sunlight.

- Operators must wear proper personal protective equipment during electrical connections.
- Must ensure that cables are voltage-free with a measuring instrument before touching DC cables.
- Respect all safety instructions listed in relevant documents about PV strings.

### DANGER

- Before electrical connections, please make sure that the inverter switch and all switches connected to the inverter are set to "OFF", otherwise electric shock may occur!
- Ensure that the inverter is undamaged and all cables are voltage free before performing electrical work.
- Do not close the AC circuit breaker until the electrical connection is completed.

### WARNING

Do not damage the ground conductor. Do not operate the product in the absence of a properly installed ground conductor. Otherwise, it may cause personal injury or product damage.

Please use measuring devices with an appropriate range. Overvoltage can damage the measuring device and cause personal injury.

Damage to the product caused by incorrect wiring is not covered by the warranty.

- Electrical connection must be performed by professionals.
- Operators must wear proper personal protective equipment during electrical connections.
- All cables used in the PV generation system must be firmly attached, properly insulated, and adequately dimensioned. Cables used shall comply with the requirements of local laws and regulations.
- The factors that affect cable selection include rated current, cable type, routing mode, ambient temperature, and maximum expected line loss.

**NOTICE**

**All electrical connections must comply with local and national/regional electrical standards.**

- **Cables used by the user shall comply with the requirements of local laws and regulations.**
- **Only with the permission of the national/regional grid department, the inverter can be connected to the grid.**
- **Requires external protection device.**
- **Requires external multipole interruption device for current carrying wires disconnection.**
- **Requires an external residual current device (DR), suitable for protection against electric shock, in accordance with the ABNT NBR 5410 standard.**
- **It is expressly recommended to use rapid shutdown methods, systems or devices on the d.c.circuit. that guarantee safety in firefighting situations.**
- **The installation of this equipment must comply with current technical standards for photovoltaic electrical installation (NBR 16690) and fire risk management in photovoltaic systems (IEC 63226).**
- **This equipment is compatible with external independent rapid shutdown devices.**

**NOTICE**

- **Install the external protective grounding cable first when performing electrical connection and remove the external protective grounding cable last when removing the inverter.**
- **Keep the AC output cable and the DC input cable close to each other during electrical connection.**
- **Comply with the safety instructions related to PV strings and the regulations related to the utility grid.**

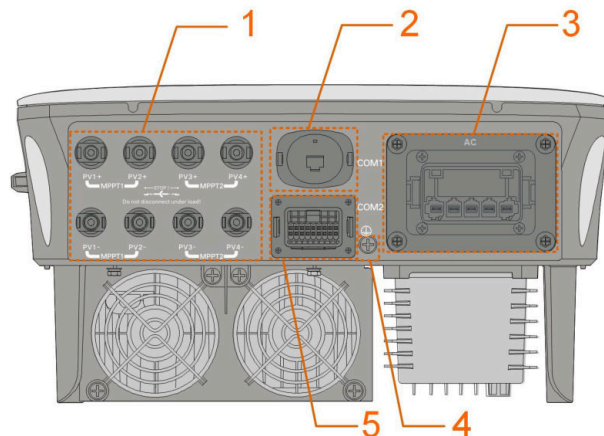
**NOTICE**

- After being crimped, the OT terminal must wrap the wires completely, and the wires must contact the OT terminal closely.
- When using a heat gun, protect the device from being scorched.
- Keep the PV+ cable and PV- cable close to each other when connecting DC input cables.
- Before connecting a power cable (such as the AC cable, the DC cable, etc.), confirm that the label and identifier on the power cable are correct.
- When laying out communication cables, separate them from power cables and keep them away from strong interference sources to prevent communication interruption.
- All vacant terminals must be covered with waterproof covers to prevent affecting the protection performance.
- Ensure that AC output cables are firmly connected. Failing to do so may cause inverter malfunction or damage to its AC connectors.
- When the wiring is completed, seal the gap at the cable inlet and outlet holes with fireproof/waterproof materials such as fireproof mud to prevent foreign matter or moisture from entering and affecting the long-term normal operation of the inverter.

The cable colors in figures in this manual are for reference only. Please select cables according to local cable standards.

## 5.2 Terminal Description


All electrical terminals are located at the bottom of the inverter.



**Figure 5-1** Terminals (SG20RT-P2 for example)

\* The image shown here is for reference only. The actual product received may differ.

**Table 5-1** Terminal Description

No.	Name	Description	Decisive Voltage Classification
1	PV1+, PV1-, PV2+, PV2-, PV3+, PV3-, PV4+, PV4-	MC4 terminals for PV input. The terminal number depends on inverter model.	DVC-C
2	COM1	Communication accessory port to be connected to WiNet-S/ WiNet-S2 for countries except Brazil or to WiFi for Brazil.	DVC-A
3	AC	AC terminal to connect to the grid.	DVC-C
4		External grounding terminal.	Not applicable
5	COM2	Communication connection for DI/DRM, DO, Logger, and meter.	DVC-A

The pin definition of COM2 terminal is shown in the following label.

RSD		NS		DRM			RS485-1	DO
RSD-1	RSD-2	NS-1	NS-2	D1/5	D3/7	R	A1	NO
B3	A3	B2	A2	D2/6	D4/8	C	B1	COM
RS485-3		Meter						

**Figure 5-2** Label of COM2 Terminal

**Table 5-2** Label Description of COM2 Terminal

Label	Description
RSD	RSD-1, RSD-2 For inverter emergency stop*
NS	NS-1, NS-2 For inverter emergency stop**
DRM	D1/5, D2/6, D3/7, D4/8, R, C For external Demand Response Enabling Device ("AU"/"NZ") For Ripple Control

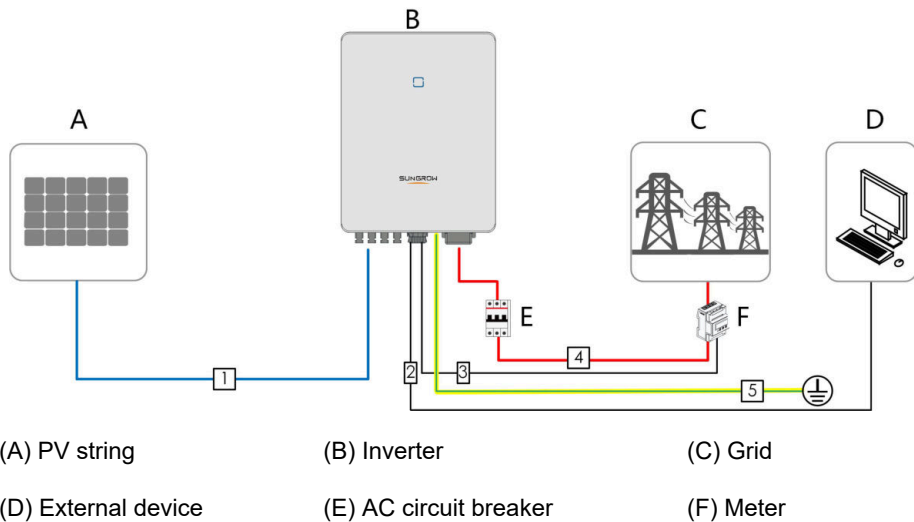
Label		Description
RS485-1	A1, B1	For inverter daisy chain (Cannot be used simultaneously with COM1 port for WiNet-S/WiNet-S2)
DO	NO, COM	External alarm interface, e.g. light indicator and/or buzzer The external DC voltage should not be higher than 30 V and the current not higher than 1 A.
RS485-3	A3, B3	Reserved
Meter	A2, B2	Meter interface

\* For SG3.0–20RT models, this terminal is reserved.

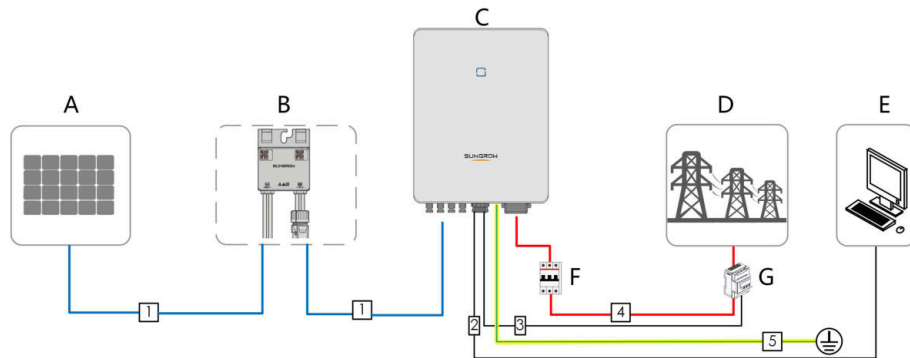
\*\* For SG3.0–20RT models, this terminal is optional.

### 5.3 Electrical Connection Overview

The SG3.0-20RT electrical connection should be realized as follows:



The SG5.0-20RT-P2 electrical connection should be realized as follows (Includes optimizer):



(A) PV string

(B) Optimizer

(C) Inverter

(D) Grid

(E) External device

(F) AC circuit breaker

(G) Meter

**Table 5-3** Cable Requirements

No.	Cable	Type	Cable Diameter	Wire Conductor Cross-section
1	DC cable	Outdoor multi-core copper wire cable complying with 1100 V and 30 A standard	6 mm–9 mm	4 mm <sup>2</sup> –6 mm <sup>2</sup>
2	Ethernet cable <sup>(3)</sup>	CAT 5E outdoor shielded network cable	5.3 mm–7 mm	8 * 0.2 mm <sup>2</sup>
3	Meter RS485 cable <sup>(1)</sup>	Shielded twisted pair	5.3 mm–7 mm	2 * (0.5–1.0) mm <sup>2</sup>
4	AC cable <sup>(2)</sup>	Outdoor 5-core copper wire cable	SG3.0RT to SG12RT, SG5.0RT–P2 to SG12RT–P2: 10 mm–21 mm	SG3.0RT to SG12RT, SG5.0RT–P2 to SG12RT–P2: 4 mm <sup>2</sup> –6 mm <sup>2</sup>
			SG15RT to SG20RT, SG15RT–P2 to SG20RT–P2: 14 mm–25 mm	SG15RT to SG20RT, SG15RT–P2 to SG20RT–P2: 6 mm <sup>2</sup> –10 mm <sup>2</sup>

No.	Cable	Type	Cable Diameter	Wire Conductor Cross-section
5	Additional Grounding cable	Outdoor single-core copper wire cable	The same as that of the PE wire in the AC cable	

(1) The cable requirements for **COM2** terminal connection are the same.

(2) All the AC wires should be equipped with correctly colored cables for distinguishing. Please refer to related standards about the wiring color.

(3) To meet shielding and anti-interference requirements:

- Shielded Ethernet cables are mandatory. It is recommended to use CAT 5E or CAT 6 shielded cables.
- Use Ethernet cables with magnet cores at both ends, and in some cases, add magnet cores in the middle.

## 5.4 External Protective Grounding Connection

### DANGER

- There are large currents during the inverter's operation. If the inverter is powered on and put into operation without being grounded, it may lead to electric shock hazards or failures of major protective functions such as surge protection. Therefore, before powering on the inverter, make sure it has been reliably grounded; otherwise, damages caused therefrom will not be covered by warranty.
- When performing electrical connections of the inverter, give the highest priority to grounding. Be sure to carry out the grounding connection first.

### WARNING

- Since the inverter is not equipped with a transformer, neither the negative electrode nor the positive electrode of the PV string can be grounded. Otherwise, the inverter will not operate normally.
- Connect the grounding terminal to the external protective grounding point before AC cable connection, PV string connection, and communication cable connection.
- The external protective grounding point provides a reliable ground connection. Do not use an improper grounding conductor for grounding. Otherwise, it may cause product damage or personal injury.
- Depending on Local Rules, please also ground the PV panel subconstruction to the same common grounding point (PE Bar) in addition to local lightning protection rules.

**⚠ WARNING**

The external protective grounding terminal must meet at least one of the following requirements.

- The cross-sectional area of the grounding cable is not less than 10 mm<sup>2</sup> for copper wire or 16 mm<sup>2</sup> for aluminum wire. It is recommended that both the external protective grounding terminal and the AC side grounding terminal be reliably grounded.
- If the cross-sectional area of the grounding cable is less than 10 mm<sup>2</sup> for copper wire or 16 mm<sup>2</sup> for aluminum wire, ensure that both the external protective grounding terminal and the AC side grounding terminal are reliably grounded.

The grounding connection can be made by other means if they are in accordance with the local standards and regulations, and SUNGROW shall not be held liable for the possible consequences.

#### 5.4.1 External Protective Grounding Requirements

All non-current carrying metal parts and device enclosures in the PV power system should be grounded, for example, brackets of PV modules and inverter enclosure.

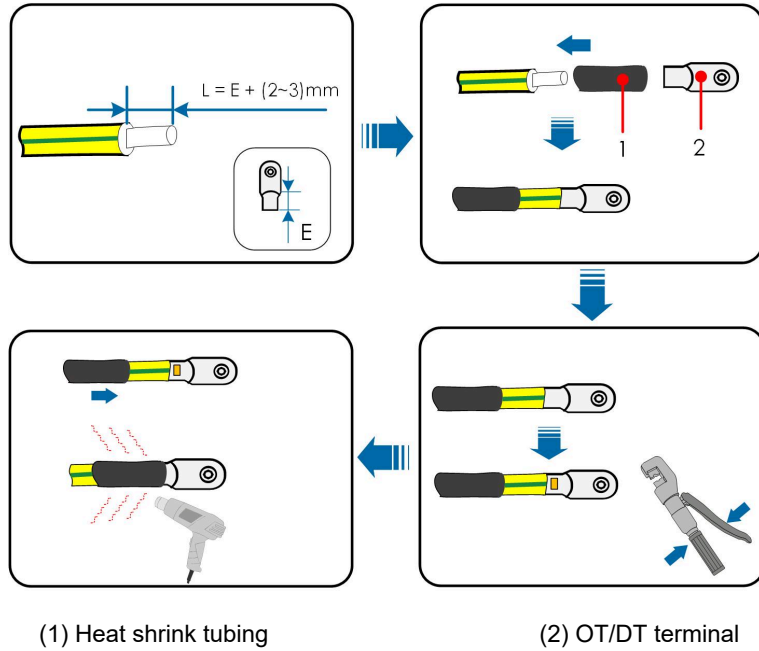
When there is only one inverter in the PV system, connect the external protective grounding cable to a nearby grounding point.

When there are multiple inverters in the PV system, connect the external protective grounding terminals of all inverters and the grounding points of the PV module brackets to ensure equipotential connections to ground cables (according to the onsite conditions).

#### 5.4.2 Connection Procedure

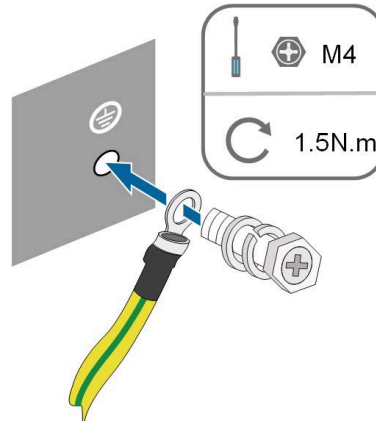
External grounding cable and OT/DT terminal are prepared by customers.

**Step 1** Prepare the cable and OT/DT terminal.



After being crimped, the OT terminal must wrap the wires completely, and the wires must contact the OT terminal closely.  
When using a heat gun, protect the device from being scorched.

**Step 2** Remove the screw on the grounding terminal and fasten the cable with a screwdriver.



**Step 3** Apply paint to the grounding terminal to ensure corrosion resistance.

--End

## 5.5 AC Cable Connection

### 5.5.1 AC Side Requirements

Only with the permission of the local grid department, the inverter can be connected to the grid.

Before connecting the inverter to the grid, ensure the grid voltage and frequency comply with requirements, for which, refer to "**Technical Data**". Otherwise, contact the electric power company for help.

#### AC Circuit Breaker

An independent three or four-pole circuit breaker must be installed on the output side of the inverter to ensure safe disconnection from the grid. The recommended specifications are as follows.

Inverter Model	Recommended Specification
SG3.0RT/SG4.0RT/SG5.0RT/ SG6.0RT/SG5.0RT-P2/SG6.0RT- P2	16 A
SG7.0RT/SG8.0RT/SG7.0RT-P2/ SG8.0RT-P2	20 A
SG10RT/SG10RT-P2	25 A
SG12RT/SG12RT-P2	32 A
SG15RT/SG17RT/SG20RT/ SG15RT-P2/SG17RT-P2/ SG20RT-P2	40 A

#### WARNING

**AC circuit breakers should be installed on the output side of the inverter and the grid side to ensure safe disconnection from the grid.**

- **Determine whether an AC circuit breaker with greater overcurrent capacity is required based on actual conditions.**
- **Do not connect any local load between the inverter and the AC circuit breaker.**
- **Multiple inverters cannot share one AC circuit breaker.**

#### Residual Current Monitoring Device

With an integrated universal current-sensitive residual current monitoring unit included, the inverter will disconnect immediately from the mains power once a fault current with a value exceeding the limit is detected.

However if an external residual current device (RCD) (type A is recommended) is mandatory, the switch must be triggered at a residual current of 300 mA (recommended). RCD of other specifications can also be used according to local standard.

In Australia, a RCD is not required according to the local standard AS3000-2018 when either of the following installation methods is adopted if the PV array capacitance to ground is large (such as a tin roof):

- Use heavy duty conduits (such as metal bushing) when run PV and AC cables through Cavity walls.
- Route the PV and AC cables through pipes (PVC or metal tubing), lay the cables and install them.

### Multiple Inverters in parallel Connection

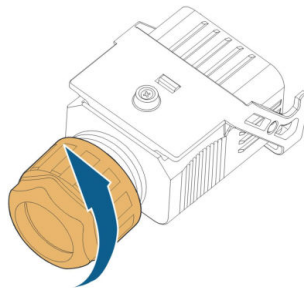
If multiple inverters are connected in parallel to the grid, ensure that the total number of parallel inverters does not exceed 5. Otherwise, please contact SUNGROW for technical scheme.

## 5.5.2 Assembling the AC Connector (< 15 kW)

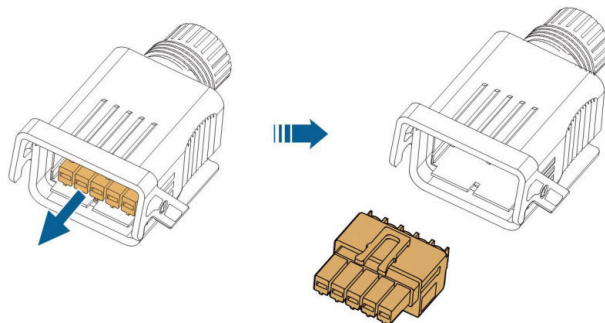
### Prerequisite

The AC terminal block is on the bottom side of the inverter. AC connection is the three-phase-four-wire grid + PE connection (L1, L2, L3, N, and PE).

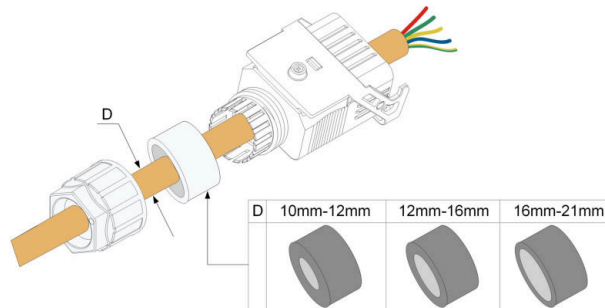
**Step 1** Unscrew the swivel nut of the AC connector.



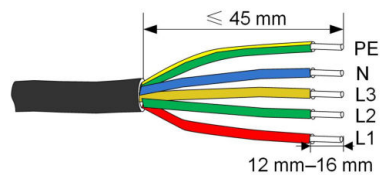
**Step 2** Take out the spring-loaded terminal from the housing.



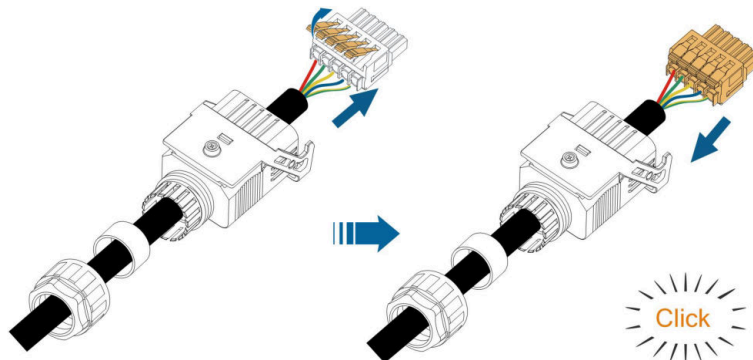
**Step 3** Thread the AC cable of appropriate length through the swivel nut, the sealing ring and the housing.



**Step 4** Remove 45 mm of the cable jacket and 12 mm–16 mm of the wire insulation.



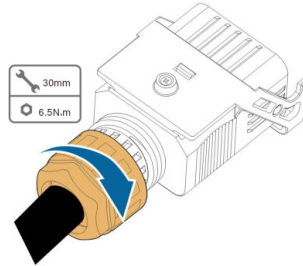
**Step 5** Open the clamp on the spring-loaded terminal and insert the wires into the corresponding holes. Close the clamp and push the terminal into the housing until there is an audible click.



#### NOTICE

**Observe the terminal assignment. Do not connect any phase line to the "PE" terminal or PE wire to "N" terminal. Otherwise, unrecoverable damage to the inverter may follow.**

**Step 6** Ensure that the wires are securely in place by slightly pulling them. Tighten the swivel nut to the housing.



--End

### 5.5.3 Installing the AC Connector (< 15 kW)

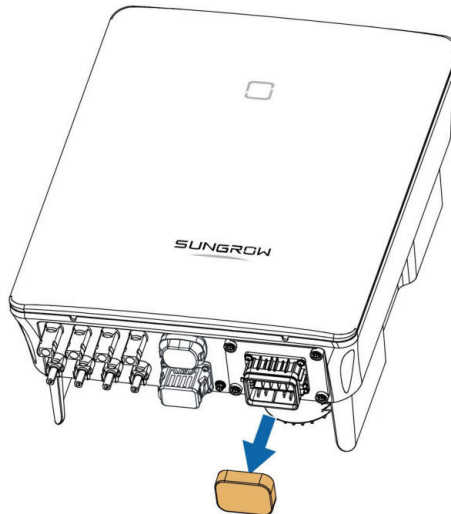
#### Prerequisite

#### **⚠ DANGER**

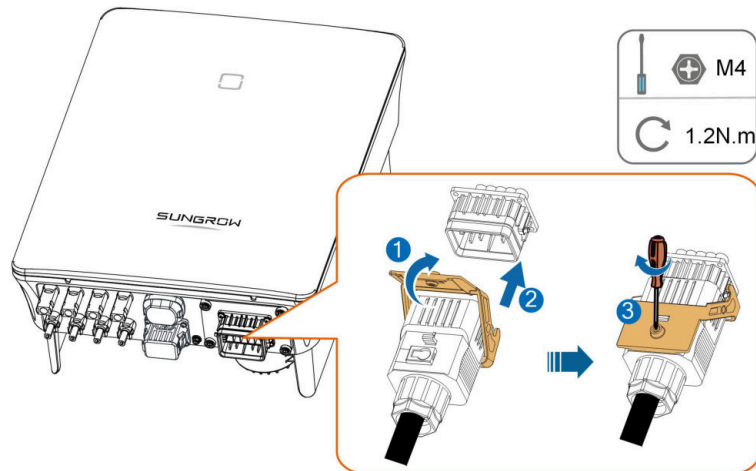
**High voltage may be present in inverter!**  
**Ensure all cables are voltage-free before electrical connection.**  
**Do not connect the AC circuit breaker until all inverter electrical connections are completed.**

**Step 1** Disconnect the AC circuit breaker and secure it against reconnection.

**Step 2** Remove the waterproof lid from the **AC** terminal.



**Step 3** Lift the locking part upwards and insert the AC connector into the **AC** terminal on the bottom side of the inverter. Then press the locking part and secure it with the screw.



**Step 4** Connect the PE wire to ground and the phase lines and the “N” line to AC circuit breaker. Then Connect the AC circuit breaker to electric board.

**Step 5** Make sure all wires are firmly installed via the right torque tool or dragging the cables slightly.

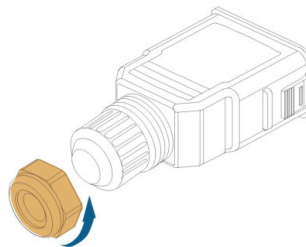
--End

#### 5.5.4 Assembling the AC Connector (≥ 15 kW)

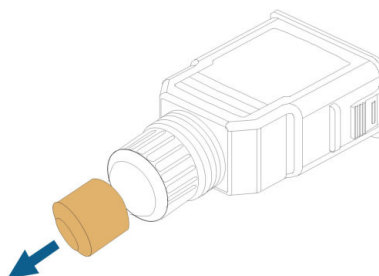
##### Prerequisite

The AC terminal block is on the bottom side of the inverter. AC connection is the three-phase-four-wire grid + PE connection (L1, L2, L3, N, and PE).

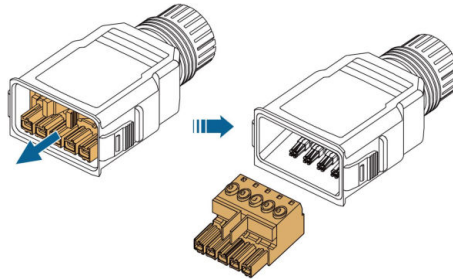
**Step 1** Unscrew the swivel nut of the AC connector.



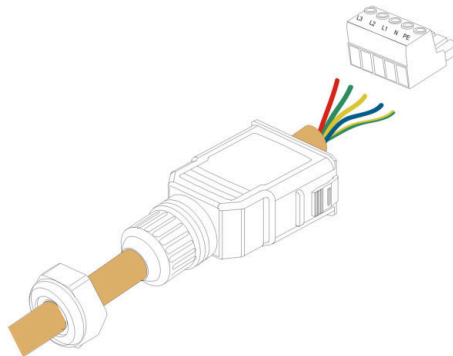
**Step 2** (Optional) Remove the inner sealing ring if the cable diameter is 19 mm–25 mm. Otherwise skip this step.



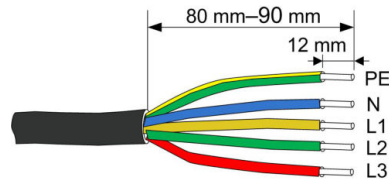
**Step 3** Take out the screw-type terminal plug from the housing.



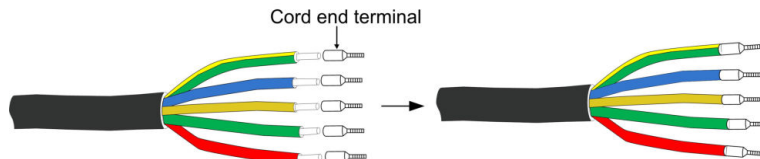
**Step 4** Thread the AC cable of appropriate length through the swivel nut and the housing.



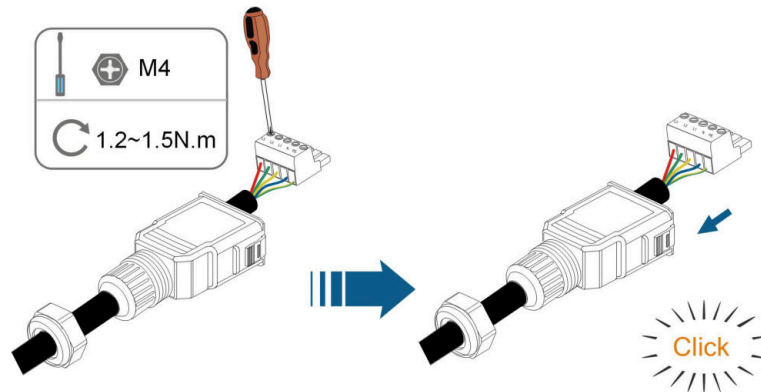
**Step 5** Remove 80 mm–90 mm of the cable jacket and 12 mm of the wire insulation.



**Step 6 (Optional)** When using a multi-core multi-strand copper wire cable, connect the AC wire head to the cord end terminal (hand-tight). In case of single-strand copper wire, skip this step.

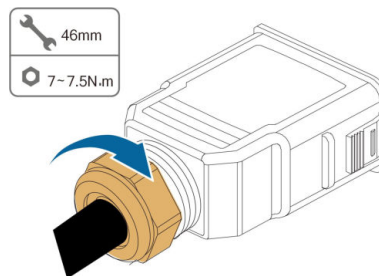


**Step 7** Fix all the wires to the screw-type terminal according to the assignment and tighten to a torque of 1.2 N•m–1.5 N•m with a screwdriver. Then push the terminal into the housing until there is an audible click.

**NOTICE**

Observe the terminal assignment. Do not connect any phase line to the "PE" terminal or PE wire to "N" terminal. Otherwise, unrecoverable damage to the inverter may follow.

**Step 8** Ensure that the wires are securely in place by slightly pulling them. Tighten the swivel nut to the housing.



--End

### 5.5.5 Installing the AC Connector (≥ 15 kW)

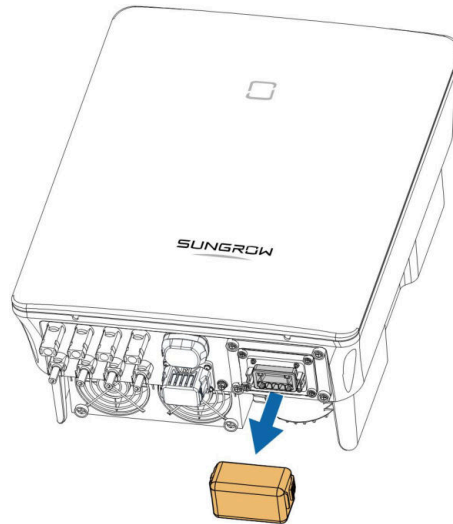
#### Prerequisite

#### **⚠ DANGER**

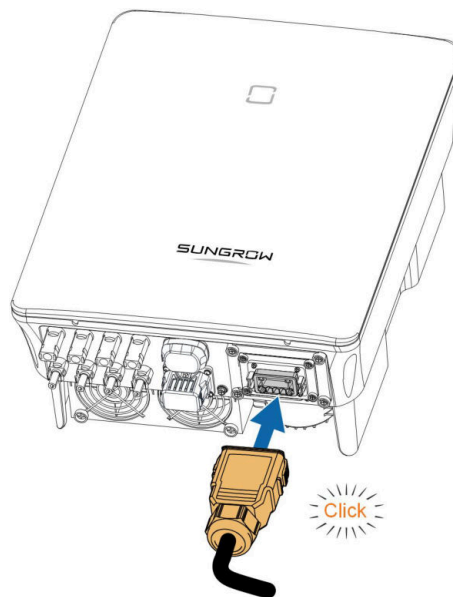
High voltage may be present in inverter!  
Ensure all cables are voltage-free before electrical connection.  
Do not connect the AC circuit breaker until all inverter electrical connections are completed.

**Step 1** Disconnect the AC circuit breaker and secure it against reconnection.

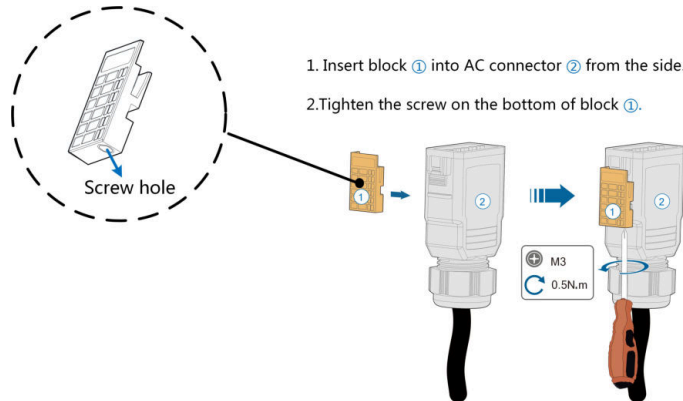
**Step 2** Remove the waterproof lid from the **AC** terminal.



**Step 3** Insert the AC connector into the **AC** terminal on the bottom of the inverter until there is an audible sound.



**Step 4 (Optional)** Secure the AC connector, as shown in the figure below.



**Step 5** Connect the PE wire to ground and the phase lines and the "N" line to AC circuit breaker. Then connect the AC circuit breaker to electric board.

**Step 6** Make sure all wires are firmly installed via the right torque tool or dragging the cables slightly.

--End

## 5.6 DC Cable Connection

### **⚠ DANGER**

The PV string will generate lethal high voltage when exposed to sunlight.

- Respect all safety instructions listed in relevant documents about PV strings.

**⚠ WARNING**

- **Make sure the PV array is well insulated to ground before connecting it to the inverter.**
- **Make sure the maximum DC voltage and the maximum short circuit current of any string never exceed inverter permitted values specified in "Technical Data".**
- **Check the positive and negative polarity of the PV strings, and connect the PV connectors to corresponding terminals only after ensuring polarity correctness.**
- **During the installation and operation of the inverter, please ensure that the positive or negative electrodes of PV strings do not short-circuit to the ground. Otherwise, an AC or DC short-circuit may occur, resulting in equipment damage. The damage caused by this is not covered by the warranty.**
- **Electric arc or contactor over-temperature may occur if the DC connectors are not firmly in place, and the loss caused is not covered by the warranty.**
- **If the DC input cables are reversely connected or the positive and negative terminals of different MPPT are shorted to ground at the same time, while the DC switch is in the "ON" position, do not operate immediately. Otherwise, the inverter may be damaged. Please turn the DC switch to "OFF" and remove the DC connector to adjust the polarity of the strings when the string current is lower than 0.5 A.**
- **Use the DC connectors supplied with the product for DC cable connection. Using incompatible DC connectors may result in serious consequences, and the device damage is not covered under warranty.**
- **Inverters do not support full parallel connection of strings (Full parallel connection refers to a connection method in that strings are connected in parallel and then connected to the inverter separately).**
- **Do not connect one PV string to multiple inverters. Otherwise, the inverters may be damaged.**

**NOTICE**

**The following requirements about PV string connection must be met. Otherwise, it may cause irreversible damage to the inverter, which is not covered by the warranty.**

- **Mixed use of PV modules of different brands or models in one MPPT circuit, or PV modules of different orientation or inclination in a string may not damage inverter, but will cause system bad performance!**
- **The inverter enters standby state when the input voltage ranges between 1,000 V and 1,100 V. The inverter returns to running state once the voltage returns to the MPPT operating voltage range, namely, 160 V to 1,000 V.**
- **The inverter enters standby state when the input voltage ranges between 560 V and 600 V. The inverter returns to running state once the voltage returns to the MPPT operating voltage range, namely, 40 V to 560 V.**

**NOTICE**

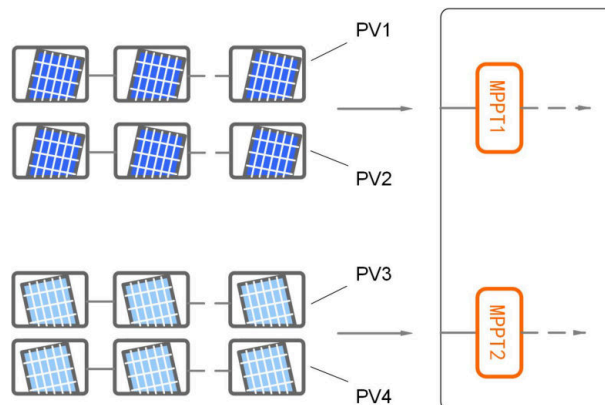
Note the following items when laying cables on site:

- The axial tension on PV connectors must not exceed 80 N. Avoid axial cable stress on the connector for a long time during field wiring.
- Radial stress or torque must not be generated on PV connectors. It may cause the connector waterproof failure and reduce connector reliability.
- Leave at least 50 mm of slack to avoid the external force generated by the cable bending affecting the waterproof performance.
- Refer to the specifications provided by the cable manufacturer for the minimum cable bending radius. If the required bending radius is less than 50 mm, reserve a bending radius of 50 mm. If the required bending radius is greater than 50 mm, reserve the required minimum bending radius during wiring.

In Australia, DC isolator shall be installed between PV modules and inverter. The DC isolator shall comply with local regulation and standard, including AS60947.3:2018.

### 5.6.1 PV Input Configuration

- The inverters SG3.0RT/SG4.0RT/SG5.0RT/SG6.0RT/SG5.0RT-P2/SG6.0RT-P2 have two PV inputs, SG7.0RT/SG8.0RT/SG10RT/SG12RT/SG7.0RT-P2/SG8.0RT-P2/SG10RT-P2/SG12RT-P2 have three PV inputs and SG15RT/SG17RT/SG20RT/SG15RT-P2/SG17RT-P2/SG20RT-P2 have four PV inputs.
- The inverters have two MPP trackers. Each DC input area can operate independently.
- The PV strings to the same DC input area should have the same type, the same number of PV panels, identical tilt and identical orientation for maximum power.
- The PV strings to two DC input areas may differ from each other, including PV module type, number of PV modules in each string, angle of tilt, and installation orientation.



**Figure 5-3** PV Input Configuration (SG20RT for example)

Prior to connecting the inverter to PV inputs, the specifications in the following table should be met:

Inverter Model	Open-circuit Voltage Limit	Max. current for input connector
All models	1100 V	30 A

The following figure shows the open-circuit voltage limits at different altitudes. Before configuring the PV panels, need to take this derating curve in consideration under high altitude situation.

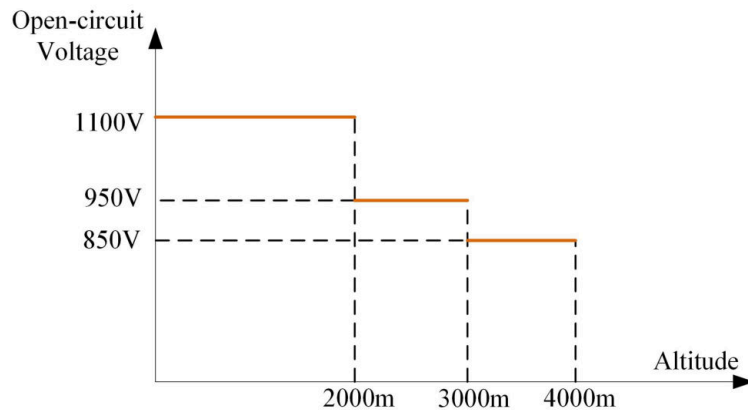


Figure 5-4 Open-circuit Voltage Derating Curve

### 5.6.2 Assembling PV Connectors

#### Prerequisite

#### **⚠ DANGER**

High voltage may be present in the inverter!

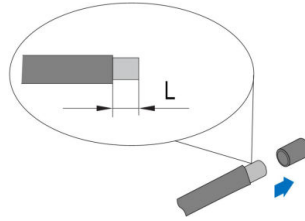
- Ensure all cables are voltage-free before performing electrical operations.
- Do not connect the AC circuit breaker before finishing electrical connection.

#### **⚠ CAUTION**

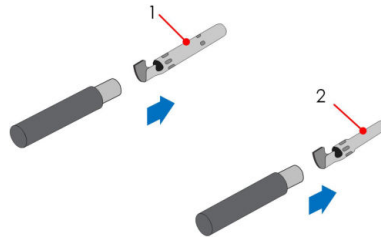
- Use MC4 DC terminals if the maximum input voltage is no more than 1,000 V.
- Use MC4-Evo2 DC terminals if the maximum input voltage is greater than 1,000 V. To purchase the MC4-Evo2 DC terminals, contact SUNGROW.
- Select appropriate DC terminals as required above. Otherwise, SUNGROW shall be held no liability for the damage caused.

To ensure IP65 protection, use only the supplied connector.

**Step 1** Strip 7 mm–8 mm of the insulation from each PV cable.



**Step 2** Assemble the cable ends with the crimping pliers.



1: Positive crimp contact

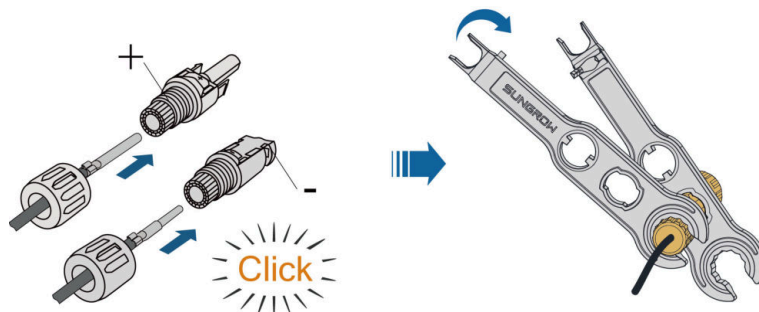
2: Negative crimp contact

**Step 3** For some countries such as Australia where the DC protection cover delivered separately need to be installed on site, please firstly lead the PV cables through the waterproof terminal on the DC protection cover before assembling the connector. See the guidance with the DC protection cover for details.

#### NOTICE

**PV cables with connectors cannot go through the waterproof terminal on the DC protection cover. Rework may cause damage to the connectors, which will not be covered by the warranty.**

**Step 4** Lead the cable through the cable gland, and insert the crimp contact into the insulator until it snaps into place. Gently pull the cable backward to ensure firm connection. Tighten the cable gland and the insulator (torque 2.5 N.m to 3 N.m).

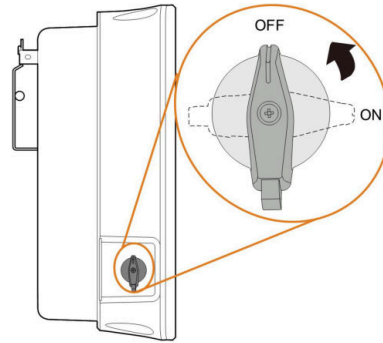


**Step 5** Check for polarity correctness.

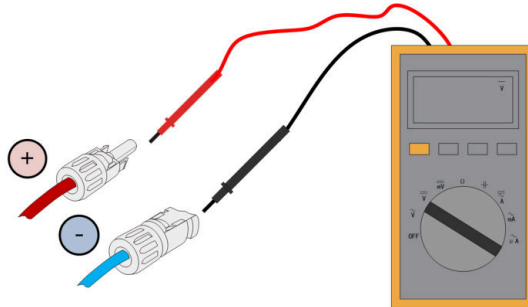
--End

### 5.6.3 Installing the PV Connectors

**Step 1** Rotate the DC switch to "OFF" position.

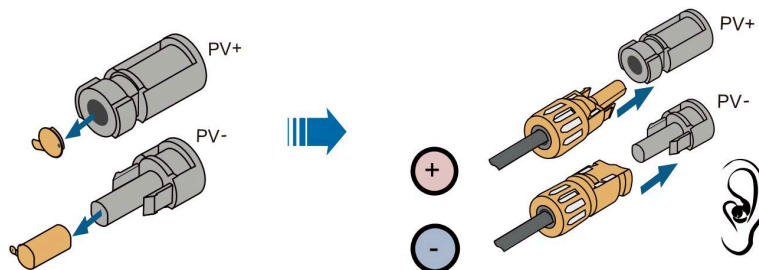


**Step 2** Check the cable connection of the PV string for polarity correctness and ensure that the open circuit voltage in any case does not exceed the inverter input limit of 1,100 V.



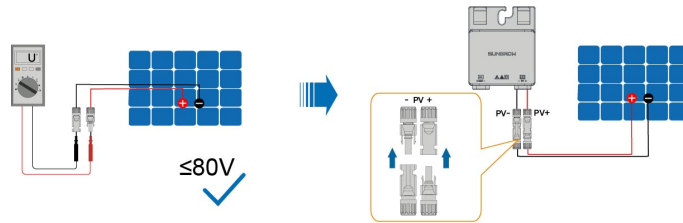
The multimeter must have a DC voltage range of at least 1100 V. If the voltage is a negative value, the DC input polarity is incorrect. Please correct the DC input polarity. If the voltage is greater than 1100V, too many PV modules are configured to the same string. Please remove some PV modules.

**Step 3** Connect the PV connectors to corresponding terminals until there is an audible click. Seal the unused PV terminals with the terminal caps.



S005-E046

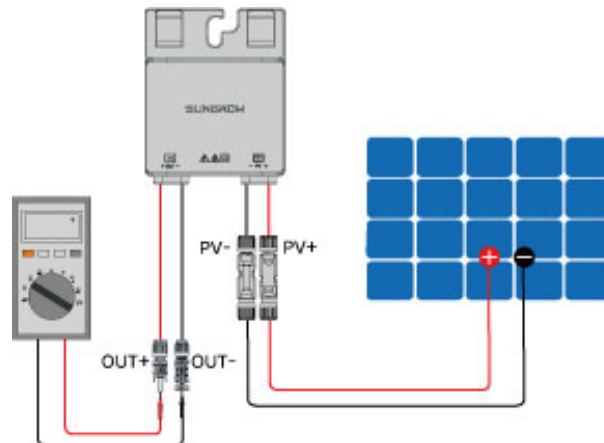
**Step 4** Connect the PV+ and PV- of the optimizer to the positive and negative terminals in the junction box of the PV module respectively.



### NOTICE

Do not connect the PV module to the OUT+ and OUT- of the optimizer. Otherwise, the optimizer or PV module will be damaged, and the loss is not covered by the warranty.

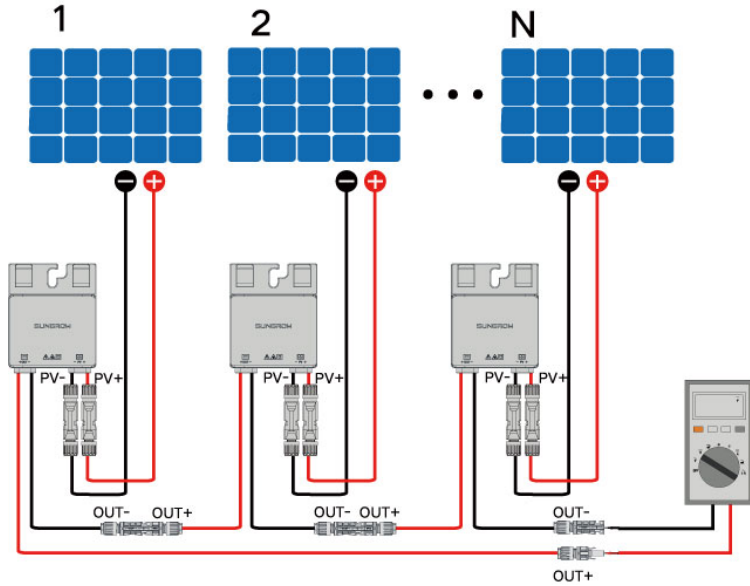
**Step 5** Connect the positive probe of a multimeter to OUT- of the optimizer, and the negative probe of the multimeter to OUT+ of the optimizer to check whether the optimizer is faulty. If typical value of output voltage is 1V, no fault occurs to the optimizer.



### NOTICE

1. Use a multimeter to measure the output voltage of each optimizer after wiring.
2. Considering the effect of the accuracy of the multimeter on the actual measurement on site, the optimizer can function normally as long as the output voltage falls in the range of 0.9V - 1.1V.
3. If the output voltage is less than 0.9 V, check the following items:
  - Check whether the sunlight is sufficient.
  - Check whether the input side of the optimizer is connected to the PV module.
  - If the fault is not caused by foregoing reasons and still persists, please replace the optimizer.
4. If the output voltage is greater than 1.1 V, the optimizer fails. Please replace the optimizer.
5. If no voltage is detected, replace the optimizer or component.

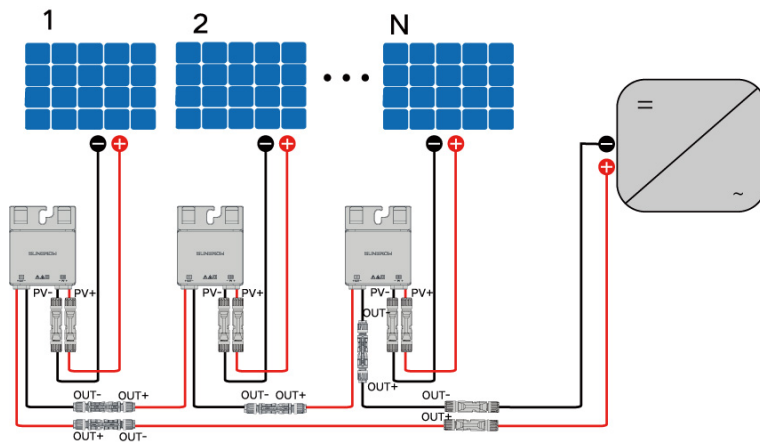
**Step 6** When connecting multiple optimizers, connect OUT- of the first optimizer to OUT+ of the second optimizer, and so on. Use a multimeter to measure the optimizer voltage. If typical value of output voltage is  $1V \times N$  (N is the number of optimizers), no fault occurs to the system.



**NOTICE**

Whether connecting OUT+ of the first optimizer to OUT- of the second optimizer or connecting OUT- of the first optimizer to OUT+ of the second optimizer is dependent on the polarity of the extension cable that is connected to the inverter on site.

**Step 7** Connect OUT+ of the first optimizer and OUT- of the last optimizer to the PV input terminals of the inverter.



**⚠ WARNING**

If each PV module is equipped with an optimizer, the total power of PV modules in a PV input shall not exceed the maximum input power of a single PV input of the inverter.

**NOTICE**

- Branch-connector connection on the input side of the inverter is not supported by the optimizer.
- Please refer to the optimizer user manual for details.



--End

## 5.7 WiNet-S/WiNet-S2 Connection

SG3.0-20RT uses WiNet-S2 module, and the WiNet-S2 module supports Ethernet communication and WLAN communication. It is not recommended to use both communication methods at the same time.

SG5.0-20RT-P2 is used with optimizer, and uses WiNet-S module. The WiNet-S module supports Ethernet communication and WLAN communication. It supports EasyConnect and can receive and transmit data of optimizers, meters, and chargers.

The WiNet-S/WiNet-S2 communication for Ethernet cannot be used simultaneously with A1 and B1 terminals for RS485 daisy chain.

For details, see the quick guide for the WiNet-S module. Scan the following QR code for the quick guide.



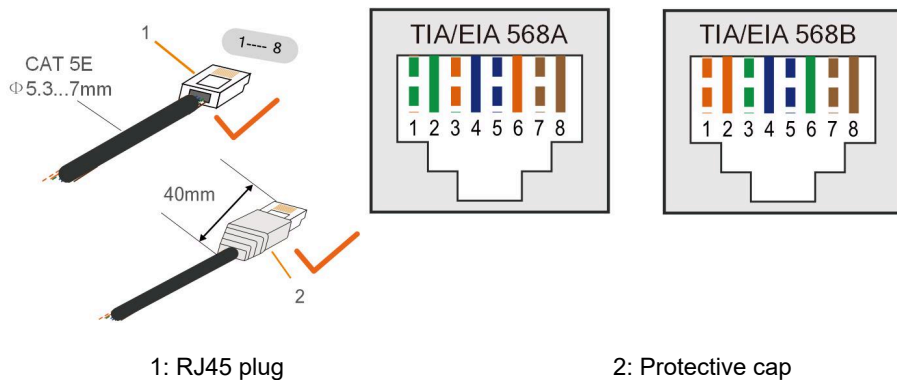
For more information about WiNet-S2, please scan the following QR code to view the quick guide.



### 5.7.1 Ethernet Communication

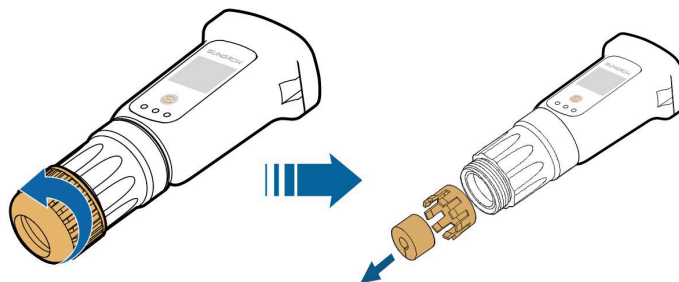
The WiNet-S/WiNet-S2 communication for Ethernet cannot be used simultaneously with A1 and B1 terminals for RS485 daisy chain.

**Step 1 (Optional)** Strip the insulation layer of the communication cable with an Ethernet wire stripper, and lead the corresponding signal cables out. Insert the stripped communication cable into the RJ45 plug in the correct order, and crimp it with a crimper.

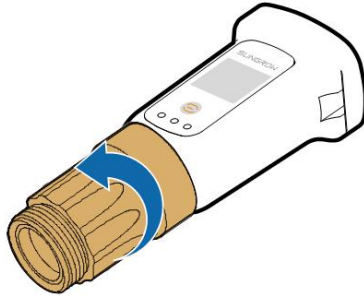


Skip this step if a standard network cable with RJ45 plug is prepared.

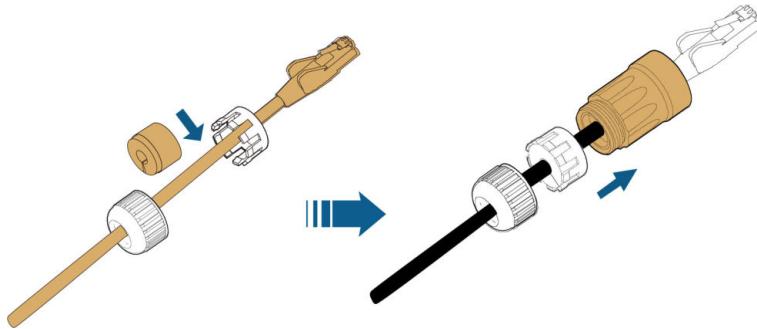
**Step 2** Unscrew the swivel nut from the communication module and take out the inner sealing ring.



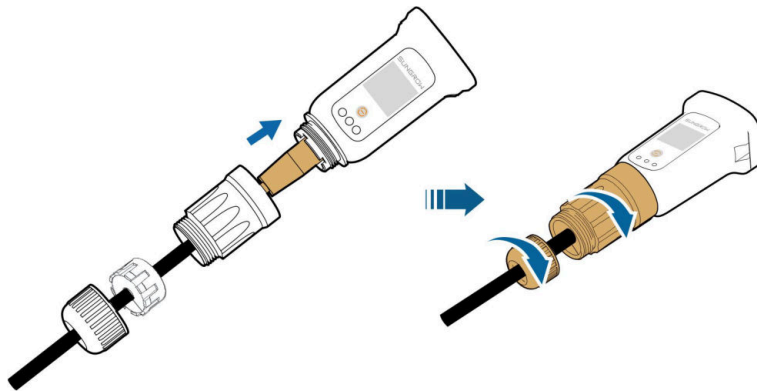
**Step 3** Unscrew the housing from the communication module.



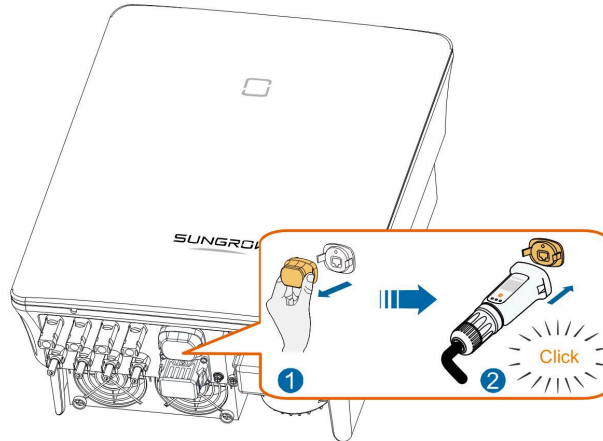
**Step 4** Thread the network cable through the swivel nut and gasket. Afterwards, route the cable into the opening of the sealing. Finally, insert the cable through the housing.



**Step 5** Insert the RJ45 plug into the front plug connector until there is an audible click and tighten the housing. Install the gasket and fasten the swivel nut.



**Step 6** Remove the waterproof lid from the **COM1** terminal and install WiNet-S/WiNet-S2.



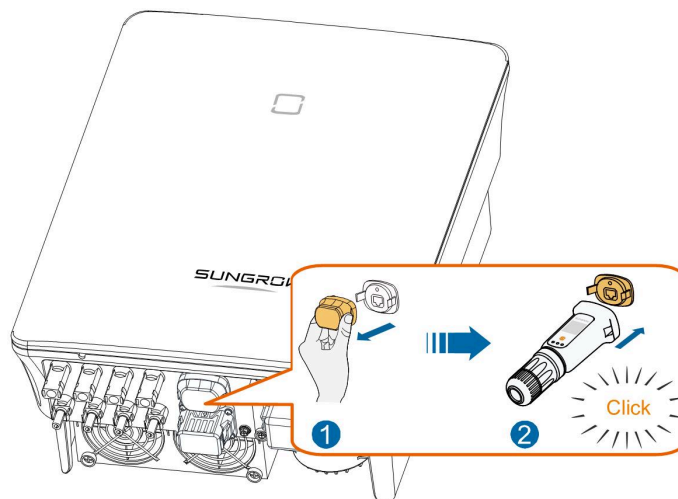
**Step 7** Slightly shake it by hand to determine whether it is installed firmly.

--End

### 5.7.2 WLAN Communication

**Step 1** Remove the waterproof lid from the **COM1** terminal.

**Step 2** Install the module. Slightly shake it by hand to determine whether it is installed firmly, as shown below.



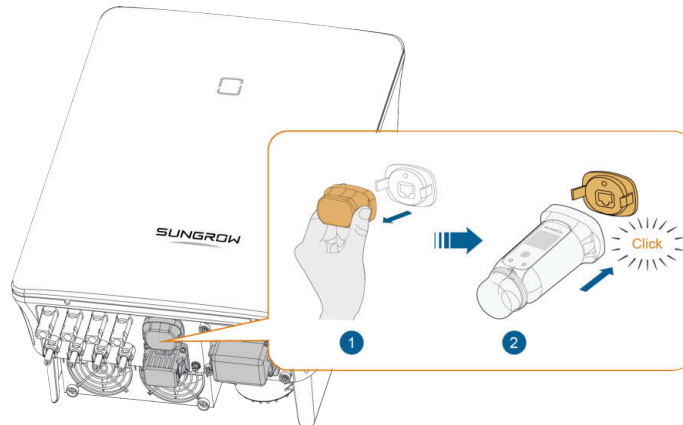
**Step 3** Refer to the guide delivered with the module for the set-up.

--End

### 5.8 WiFi-P2 Connection (for Brazil)

**Step 1** Remove the waterproof lid from the **COM1** terminal.

**Step 2** Install the module. Slightly shake it by hand to determine whether it is installed firmly, as shown below.



**Step 3** Refer to the guide delivered with the module for the set-up.

--End

## 5.9 Meter Connection

In a single inverter scenario, the meter (A2, B2) terminals are designed to connect to the meter for the feed-in power function. The export control functionality has not been tested to AS/NZS 4777.2:2020.

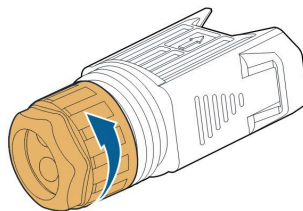
The energy meter is mainly used to detect the direction and magnitude of the current. And the energy meter data may not be used for billing purposes.

### NOTICE

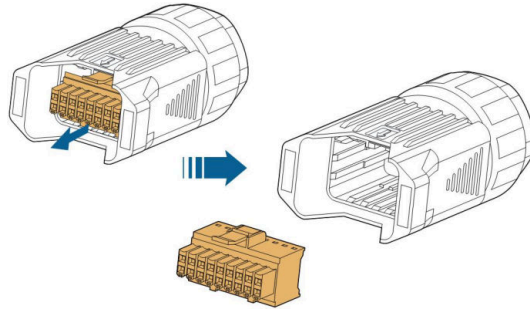
**The meter is mainly used to detect the direction and magnitude of the current. And the meter data may not be used for billing purposes.**

### 5.9.1 Assembling the COM Connector

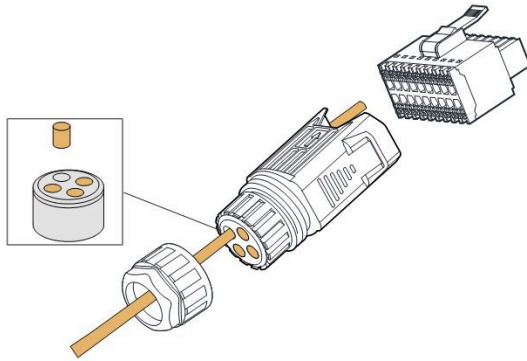
**Step 1** Unscrew the swivel nut from the connector.



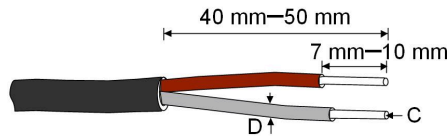
**Step 2** Take out the terminal block.



**Step 3** Remove the seal and lead the cable through the cable gland.

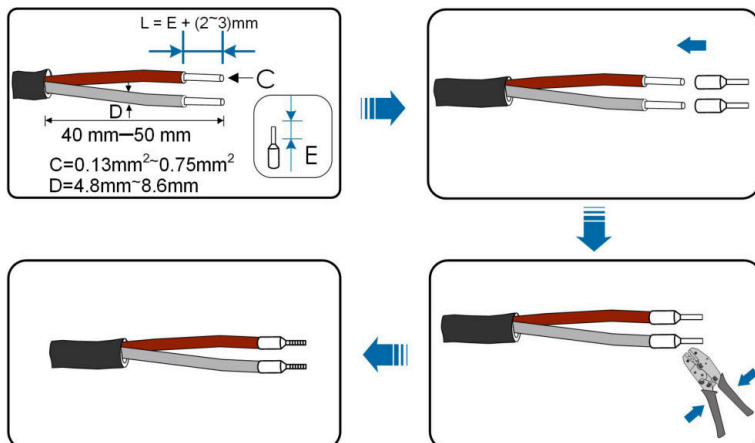


**Step 4** Remove the cable jacket and strip the wire insulation.

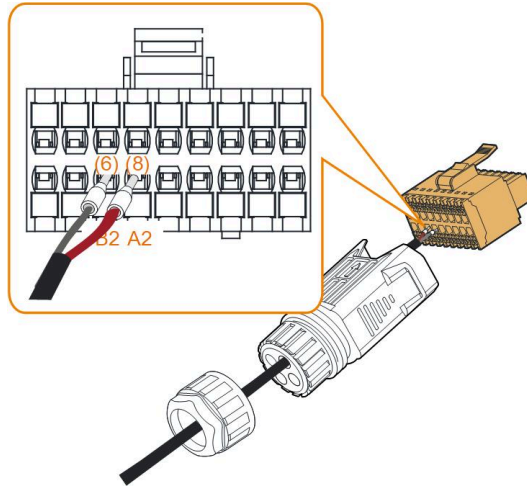


$$C = 0.5 \text{ mm}^2 - 1.0 \text{ mm}^2, D \leq 2.8 \text{ mm}$$

**Step 5** (Optional) When using a multi-core multi-strand wire cable, connect the wire head to the cord end terminal. In case of single-strand copper wire, skip this step.

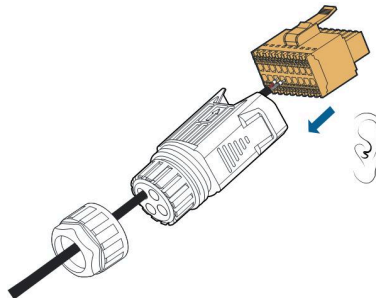


**Step 6** Plug the wires or terminals into the corresponding terminals as shown in the following figure.

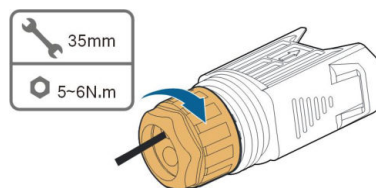


**Figure 5-5** A2, B2 connection

**Step 7** Ensure that the wires are securely in place by slightly pulling them and insert the terminal plug into the housing until there is an audible click.



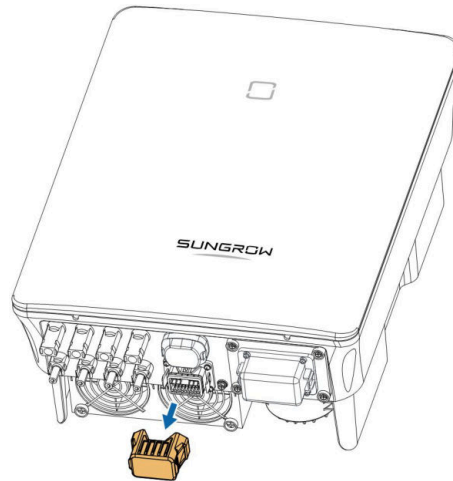
**Step 8** Fasten the swivel nut.



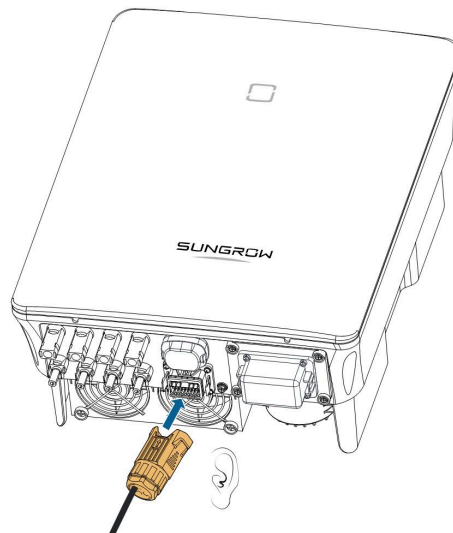
--End

### 5.9.2 Installing the COM Connector

**Step 1** Remove the waterproof lid from the **COM2** connector.



**Step 2** Insert the COM connector into **COM2** terminal on the bottom of the inverter until there is an audible click.



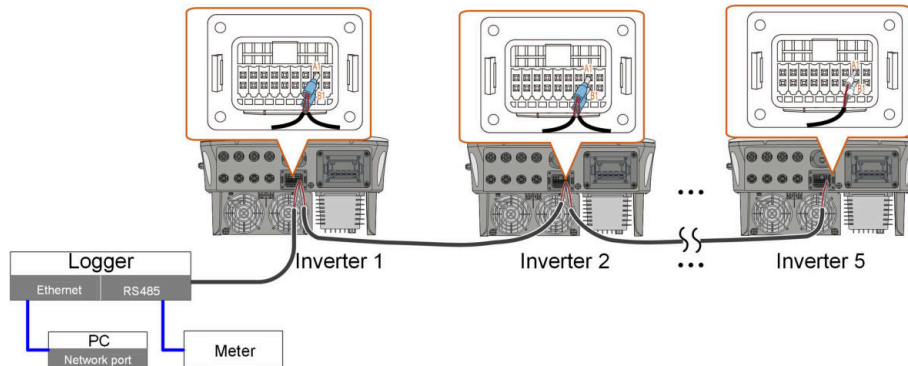
--End

## 5.10 RS485 Connection

### 5.10.1 RS485 Communication System

The RS485 (A1, B1) connection can establish the communication between the inverter and an external device, as well as the communication between two inverters in parallel.

In case of multiple inverters, all the inverters can be connected via RS485 cables in daisy chain manner.

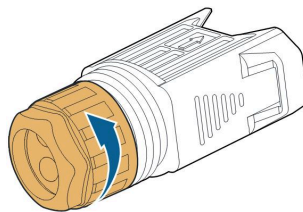


**Figure 5-6** Multi-inverter Connection

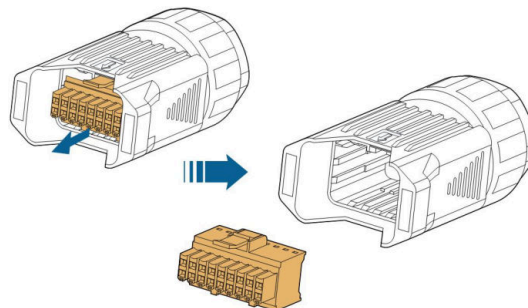
- The maximum number of inverters allowed to be connected in the same point of connection is 5.
- The RS485 communication cable should be shielded twisted pair cables or shielded twisted pair Ethernet cables.
- The RS485 cable between two devices should be not longer than 10 m.
- The RS485 communication cannot be used simultaneously with COM1 port for WiNet-S/WiNet-S2.
- Refer to the manual of Logger for the communication connection to the meter.

### 5.10.2 Assembling the COM Connector

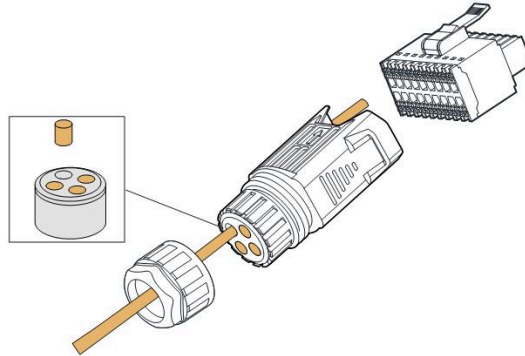
**Step 1** Unscrew the swivel nut from the connector.



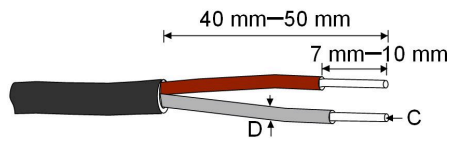
**Step 2** Take out the terminal block.



**Step 3** Remove the seal and lead the cable through the cable gland.

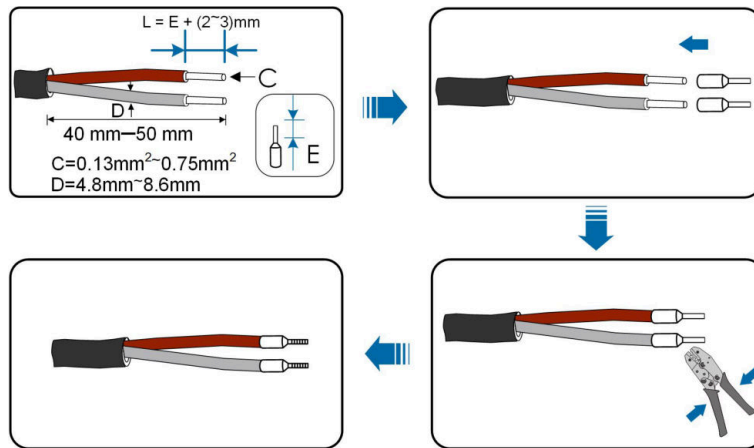


**Step 4** Remove the cable jacket and strip the wire insulation.

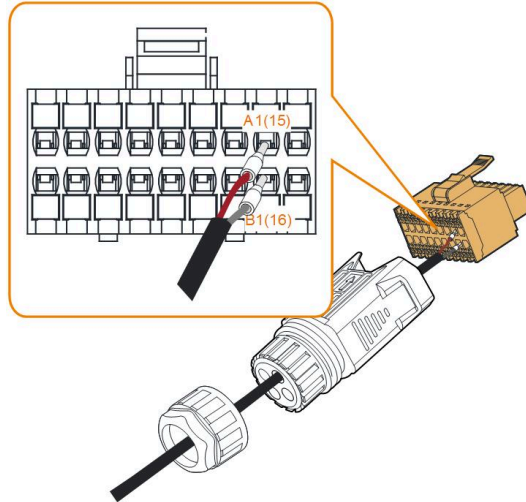


$$C = 0.5 \text{ mm}^2 - 1.0 \text{ mm}^2, D \leq 2.8 \text{ mm}$$

**Step 5** (Optional) When using a multi-core multi-strand wire cable, connect the wire head to the cord end terminal. In case of single-strand copper wire, skip this step.

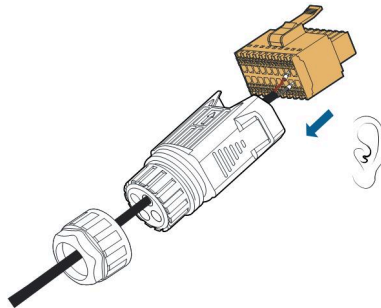


**Step 6** Plug the wires or terminals into the corresponding terminals as shown in the following figure.

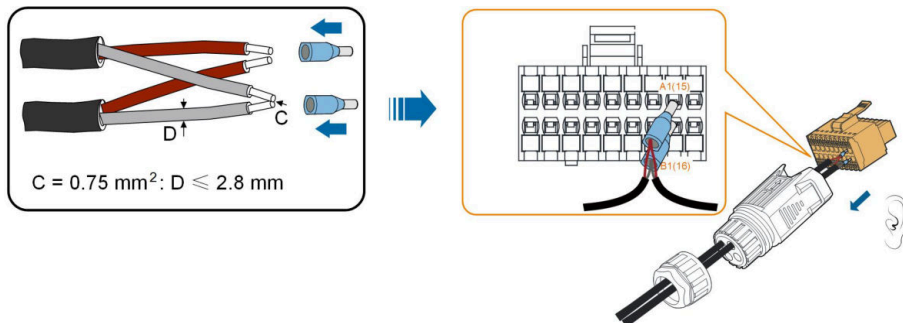


**Figure 5-7** A1, B1 connection

**Step 7** Ensure that the wires are securely in place by slightly pulling them and insert the terminal plug into the housing until there is an audible click.

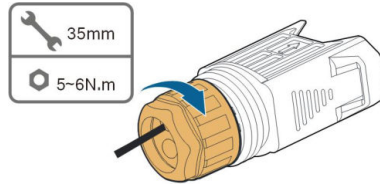


**Step 8** For RS485 daisy chain: Crimp two wires A to a two-wire core end terminal and two wires B to another terminal. Plug the terminals to A1 and B1 respectively.



**Figure 5-8** RS485 daisy chain connection

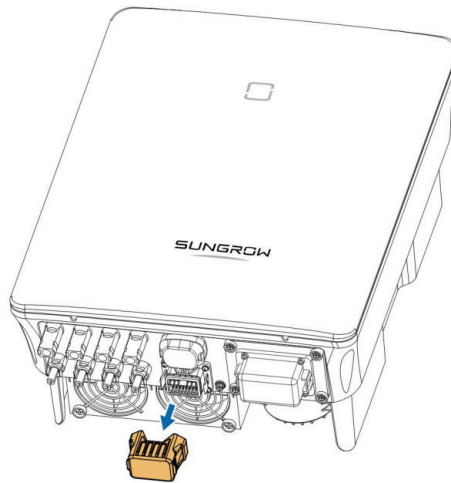
**Step 9** Fasten the swivel nut.



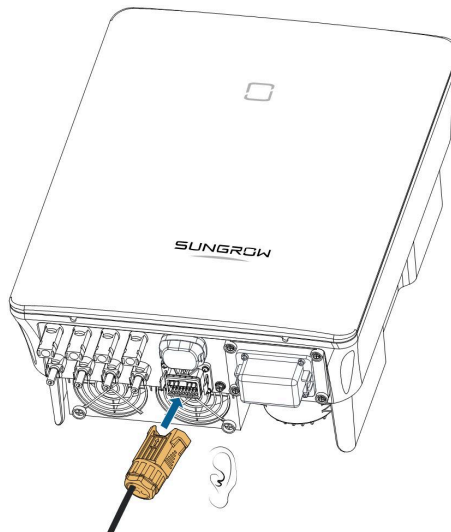
--End

### 5.10.3 Installing the COM Connector

**Step 1** Remove the waterproof lid from the **COM2** connector.



**Step 2** Insert the COM connector into **COM2** terminal on the bottom of the inverter until there is an audible click.

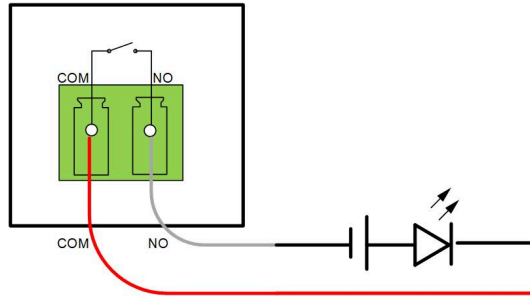


--End

## 5.11 DO Connection

The inverter is equipped with a DO relay for an earth fault alarm. The additional equipment required is a light indicator and/or a buzzer that needs additional power supply.

Once fault occurs, the relay trips and the circuit is connected. The external indicator gets on. The relay remains triggered until the fault is removed.

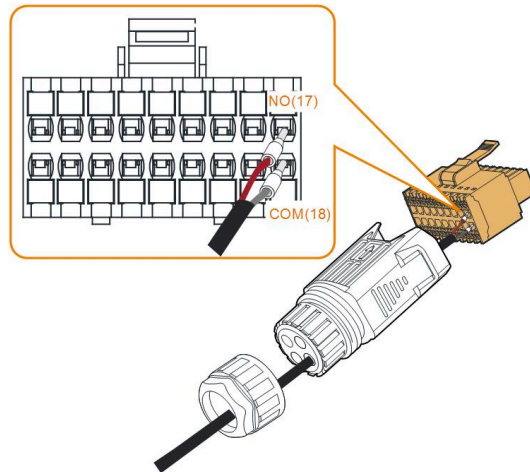


**Figure 5-9** DO Normal Open Connect

The additional DC power supply should comply with related requirements:

- Max. voltage: 30 V
- Max. current: 1 A

Refer to section [5.9.1 Assembling the COM Connector](#) for detailed assembling procedure. Plug the wires to **NO** and **COM** terminals according to the labels on the bottom of the inverter.

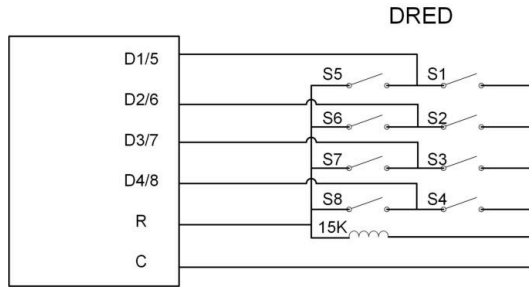


Refer to section [5.9.2 Installing the COM Connector](#) to install the connector.

## 5.12 DRM Connection

In Australia and New Zealand, the inverter supports the demand response modes as specified in the standard AS/NZS 4777.

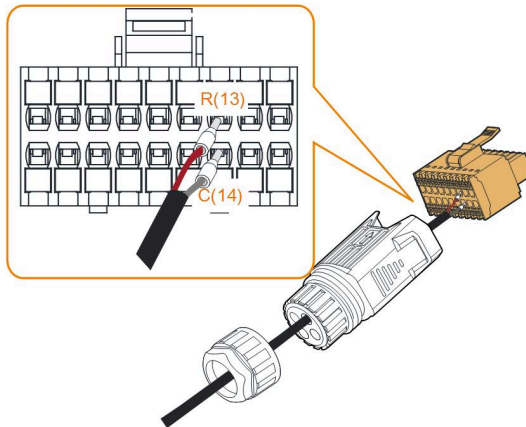
The following figure shows the wiring between the inverter and the external DRED.



**Table 5-4** Method of Asserting DRM

Mode	Asserted by Shorting Terminals on Inverter	Switch Operation on External DRED
DRM 0	R & C	Close S1 and S5

Refer to section [5.9.1 Assembling the COM Connector](#) for detailed assembling procedure. Plug the wires to **R** and **C** terminals according the labels on the bottom of the inverter.

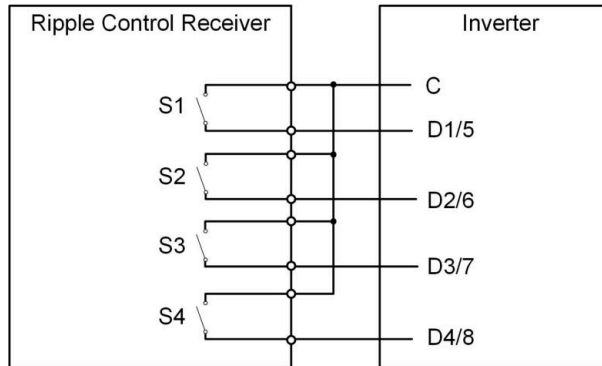


Refer to section [5.9.2 Installing the COM Connector](#) to install the connector.

### 5.13 DI Connection

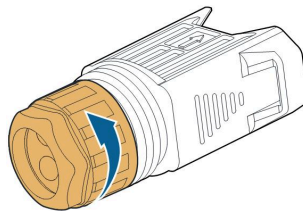
The grid company uses a Ripple Control Receiver to convert the grid dispatching signal and send it as a dry contact signal.

The following figure shows the wiring between the inverter and the ripple control receiver.

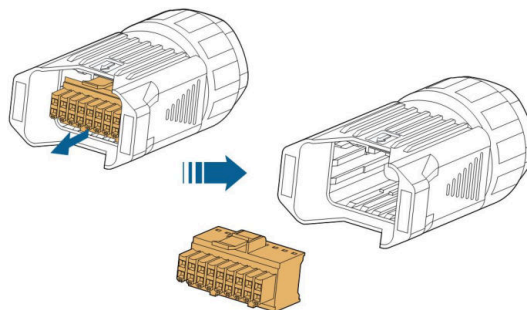
**Table 5-5** Method of Asserting DI Mode

S1	S2	S3	S4	Switch Operation on External RCR	Output power (in % of the Rated AC output power)
0	0	0	0	None	100 % (configurable according to need)
1	0	0	0	Close S1	100 %
0	1	0	0	Close S2	60 %
0	0	1	0	Close S3	30 %
1	1	0	0	Close S1 and S2	0 % (disconnect from grid)

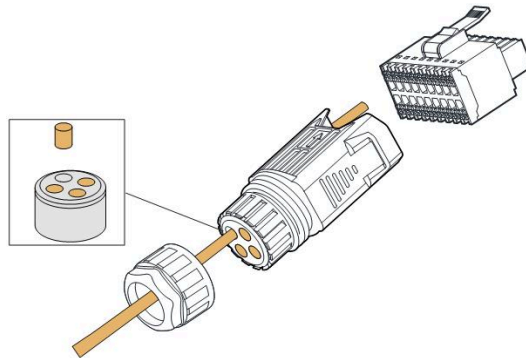
**Step 1** Unscrew the swivel nut from the connector.



**Step 2** Take out the terminal block.



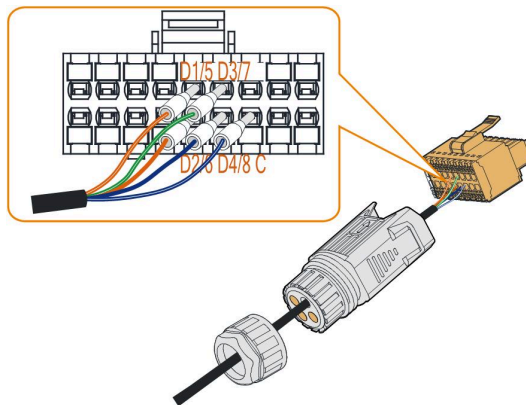
**Step 3** Remove the seal and lead the cable through the cable gland.



**Step 4** Remove the cable jacket by 7 mm–10 mm.

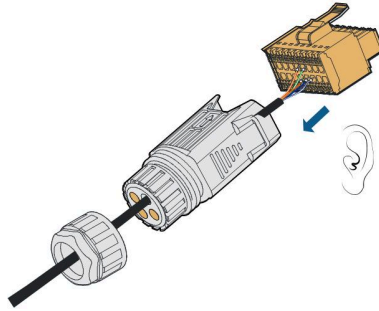


**Step 5** Plug the wires into the corresponding terminals as shown in the following figure.

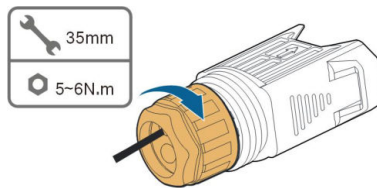


**Figure 5-10** DI connection

**Step 6** Ensure that the wires are securely in place by slightly pulling them and insert the terminal plug into the housing until there is an audible click.



**Step 7** Fasten the swivel nut.



**Step 8** Refer to section [5.9.2 Installing the COM Connector](#) to install the connector.

--End

## 5.14 NS Protection Connection

NS terminal: NS Protection is used for the German market currently. For plants sized more than 30kVA, inverter NS Protection terminals could be used in daisy chain to external NS Protection Relay to realize emergency stop when the NS Protection Relay changes its dry contact status due to the grid abnormal running status. For detailed assembling procedure for inverters in daisy chain mode refer to section [5.10.2 Assembling the COM Connector](#).

For SG3.0-20RT, NS Protection(including Passive Valid) can be set. When NS-1 and NS-2 are connected, the inverters will emergently stop; otherwise, the inverters will operate normally.

You can log in via local access to the iSolarCloud App, Tap **Settings > Operation Parameters > Regular Parameters** to enter the corresponding screen, on which you can set the "NS Protection(Passive Valid)". When the NS Protection(Passive Valid) button is set to green, the Passive Valid mode is turned on. When the NS Protection(Passive Valid) button is set to gray, the Active Valid mode is turned on.

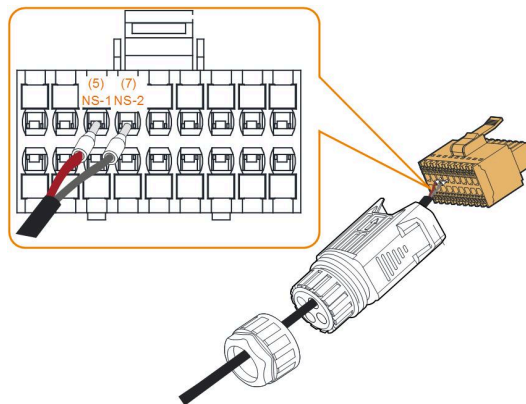
But if NS Protection is enabled on the iSolarCloud. The inverters will operate normally when NS-1 and NS-2 are connected, and the inverters will emergently stop when NS-1 and NS-2 are disconnected. See the table below for details.

**Table 5-6**

	<b>NS-1 and NS-2</b>	<b>Inverter</b>
NS Protection is disabled on iSolarCloud	Shorted	Emergency stop
	Disconnected	Normal operation
NS Protection is enabled on iSolarCloud	Shorted	Normal operation
	Disconnected	Emergency stop

The recommended wire conductor cross-section is 0.5 - 0.75 mm<sup>2</sup>, and the maximum wiring distance of NS protection loop must be less than 100 m.

Refer to section [5.9.1 Assembling the COM Connector](#) for detailed assembling procedure. Plug the wires to **NS-1** and **NS-2** terminals according to the labels on the bottom of the inverter. When terminals **NS-1** and **NS-2** are turned on by the external NS protection relay, the inverter will stop immediately.



Refer to section [5.9.2 Installing the COM Connector](#) to install the connector.

SG5.0-20RT-P2 can be used with optimizers. NS-1 and NS-2, as well as RSD-1 and RSD-2 can be used for emergency stop. See the table below for details:

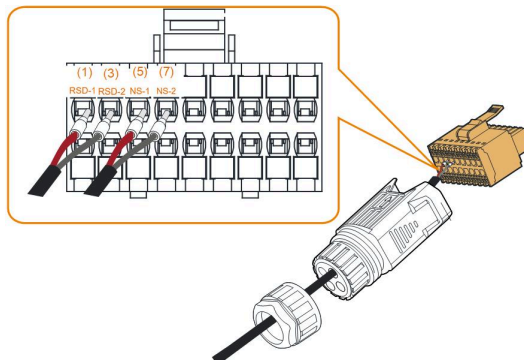
**Table 5-7**

	<b>NS-1 and NS-2</b>	<b>RSD-1 and RSD-2</b>	<b>Whether the system contains optimizers</b>	<b>Inverter</b>
NS Protection (including Passive Valid) is disabled	Shorted	Shorted	No	Emergency stop
			Yes	The inverter is in the standby status if the DC voltage is greater than 40 V

	NS-1 and NS-2	RSD-1 and RSD-2	Whether the system contains optimizers	Inverter
on iSolarCloud			No	The inverter is in the emergency stop status if the DC voltage is lower than 40 V Emergency stop
			Yes	The inverter is in the standby status if the DC voltage is greater than 40 V The inverter is in the emergency stop status if the DC voltage is lower than 40 V
		Disconnected	No	Emergency stop
			Yes	The inverter is in the standby status if the DC voltage is greater than 40 V The inverter is in the emergency stop status if the DC voltage is lower than 40 V
NS Protection (including Passive Valid) is enabled on iSolarCloud	Shorted	Disconnected	No	Normal operation
			Yes	Normal operation
		Shorted	No	Normal operation
			Yes	Normal operation
		Disconnected	No	Emergency stop
			Yes	The inverter is in the standby status if the DC voltage is greater than 40 V

NS-1 and NS-2	RSD-1 and RSD-2	Whether the system contains optimizers	Inverter
			The inverter is in the emergency stop status if the DC voltage is lower than 40 V
		No	Emergency stop
	Shorted	Yes	The inverter is in the standby status if the DC voltage is greater than 40 V The inverter is in the emergency stop status if the DC voltage is lower than 40 V
Disconnected		No	Emergency stop
	Disconnected	Yes	The inverter is in the standby status if the DC voltage is greater than 40 V The inverter is in the emergency stop status if the DC voltage is lower than 40 V

Refer to the figure below for short connection between NS-1 and NS-2, RSD-1 and RSD-2.



Refer to section [5.9.1 Assembling the COM Connector](#), [5.9.2 Installing the COM Connector](#) for detailed assembling procedure.

# 6 Commissioning

## 6.1 Inspection Before Commissioning

Check the following items before starting the inverter:

- All equipment has been reliably installed.
- DC switch(es) and AC circuit breaker are in the "OFF" position.
- The ground cable is properly and reliably connected.
- The AC cable is properly and reliably connected.
- The DC cable is properly and reliably connected.
- The communication cable is properly and reliably connected.
- The unused terminals are sealed.
- No foreign items, such as tools, are left on the top of the machine or in the junction box (if there is).
- The AC circuit breaker is selected in accordance with the requirements of this manual and local standards.
- All warning signs & labels are intact and legible.

## 6.2 Powering on the System

### Prerequisite

If all of the items mentioned above meet the requirements, proceed as follows to start up the inverter for the first time.

**Step 1** Turn on the AC circuit breaker between the inverter and the grid.

**Step 2** Rotate the DC switch of the inverter to "ON" position.

**Step 3** Turn on the external DC switch (if applicable) between the inverter and the PV string.

**Step 4** If the irradiation and grid conditions meet requirements, the inverter will operate normally. Observe the LED indicator to ensure that the inverter operates normally. Refer to [2.4 LED Indicator](#) for details.

**Step 5** Refer to the quick guide for communication module for its indicator definition.

**Step 6** Set initial protection parameters via the iSolarCloud App.

--End

**NOTICE**

- **Before closing the AC circuit breaker between the inverter and the power grid, use a multimeter that is set to the AC gear to ensure that the AC voltage is within the specified range. Otherwise, the inverter may be damaged.**
- **If the DC side is powered up while the AC side is not, the inverter indicator may turn red, and the inverter will report a fault named “Grid Power Outage” (the fault information can be viewed on the iSolarCloud App, see “Records” for details). The fault is automatically cleared when the AC circuit breaker between the inverter and the grid is closed.**

## 6.3 App Preparation

**Step 1** Install the iSolarCloud App with latest version. Refer to [7.2 Install iSolarCloud](#).

**Step 2** Register an account. Refer to [7.4 Device Commissioning](#). If you have got the account and password from the distributor/installer or SUNGROW, skip this step.


**Step 3** Download the firmware package to the mobile device in advance. Refer to [7.4 Device Commissioning](#). This is to avoid download failure due to poor on-site network signal.

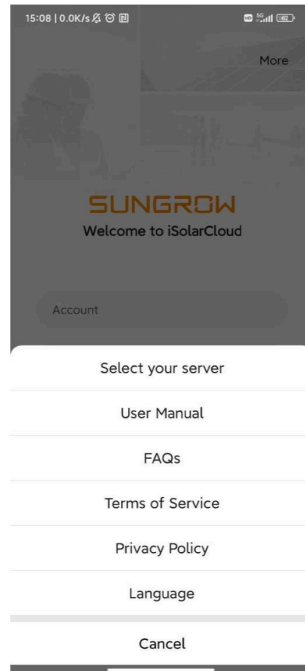
--End

## 6.4 Plant Creation

Prerequisites:


- The account and password for logging in to iSolarCloud App have been obtained from the distributor/installer or SUNGROW.
- The communication device is normally connected to the inverter.
- System positioning is enabled and iSolarCloud App is allowed to access location information.

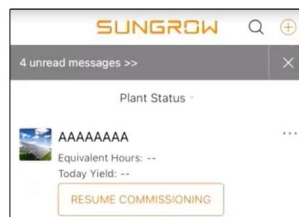
**Step 1** Open the App, tap  in the upper right corner of the interface, and select the correct access address.



**Figure 6-1** Select Access Address

**Step 2** Enter the account and password on the login interface, and tap **LOGIN** to log in.


**Step 3** Tap  in the upper right corner to enter the plant creation interface.



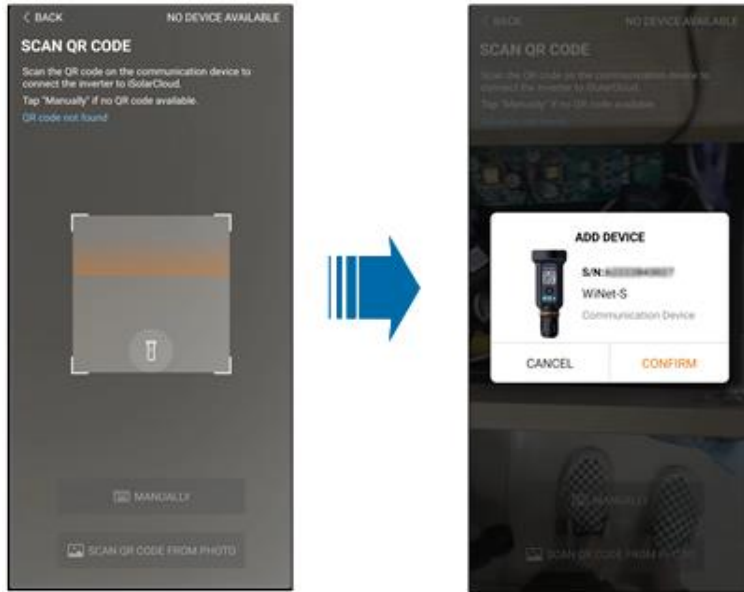
**Step 4** Fill in the content according to actual needs, and the parameters containing \* are required. Tap **Next** to enter the next interface.

Figure 6-2 Plant Creation Settings

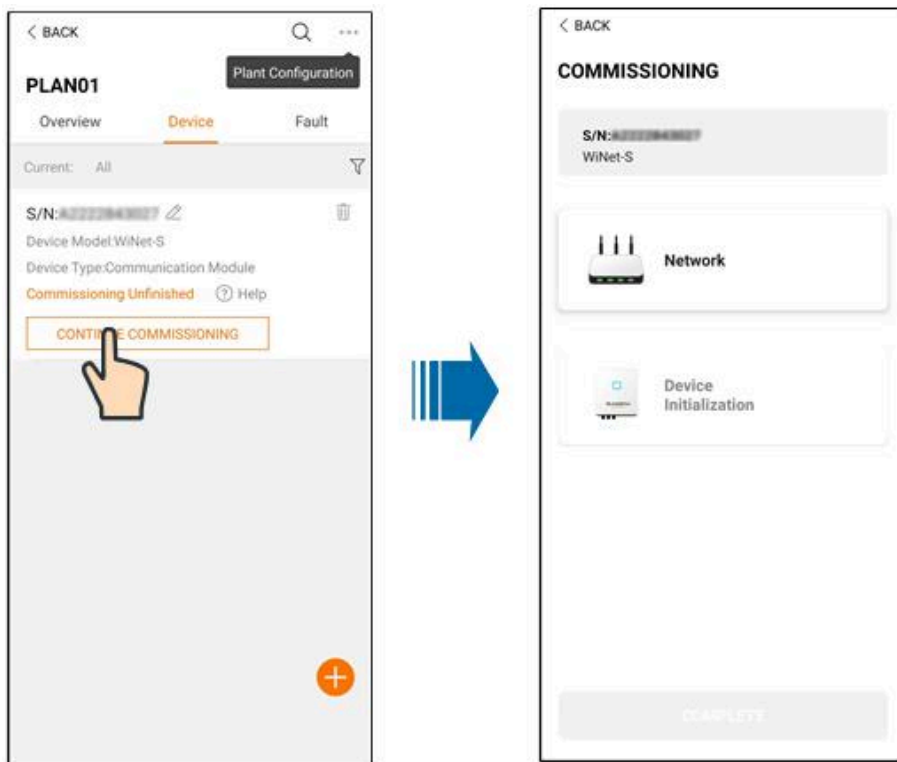
Parameter Name	Description
Plant name	The name of the plant.
Plant type	The type of the plant, which should be set corresponding to the actual plant type.
Installed power	The installed power of the plant.
Country/Region	The country/region where the plant is located.
Time zone	The time zone where the plant is located, which can be filled through automatic positioning and manual input.

Parameter Name	Description
Plant address	<p>The location of the plant, which can be filled in two ways:</p> <ul style="list-style-type: none"> <li>Manually: Manually enter the plant location in the input box.</li> <li>Automatically: Tap  to automatically obtain the current location or search for the location of the plant, and then tap <b>Confirm</b>.</li> </ul>
Grid-connection type	The way the plant is connected to the grid, including <b>100% Feed-in</b> , <b>Self-Consumption</b> , <b>Zero Export</b> , and <b>Off-grid</b> .
Grid-connected date	The time when the plant is connected to the grid.
Owner's email address	Fill in the owner information of the plant, and both registered and unregistered email addresses are supported.
Postal code	The postal code of the place where the plant is located.
Plant image	Take photos of the plant and upload them.
Feed-in tariff	<p>The feed-in tariff can be set in two ways:</p> <ul style="list-style-type: none"> <li>Enter the feed-in tariff directly in the input box.</li> <li>Tap <b>More Configurations</b>, select the tariff unit, enter the feed-in tariff, and tap <b>Confirm</b>. Enable <b>Time-of-Use Tariff</b> if needed. Tap <b>Add Time-of-Use Tariff</b>, add time intervals and price, and tap <b>Confirm</b>. Please note that if <b>Time-of-use Tariff</b> is enabled, the time periods shall cover 24 hours a day, and can not overlap.</li> </ul>
Consumption tariff	<p>Set the consumption tariff as follows:</p> <ul style="list-style-type: none"> <li>Tap <b>More Configurations</b>, select the tariff unit, enter the consumption tariff, and tap <b>Confirm</b>. Enable <b>Time-of-Use Tariff</b> if needed, and refer to the setting methods of the feed-in tariff.</li> </ul>

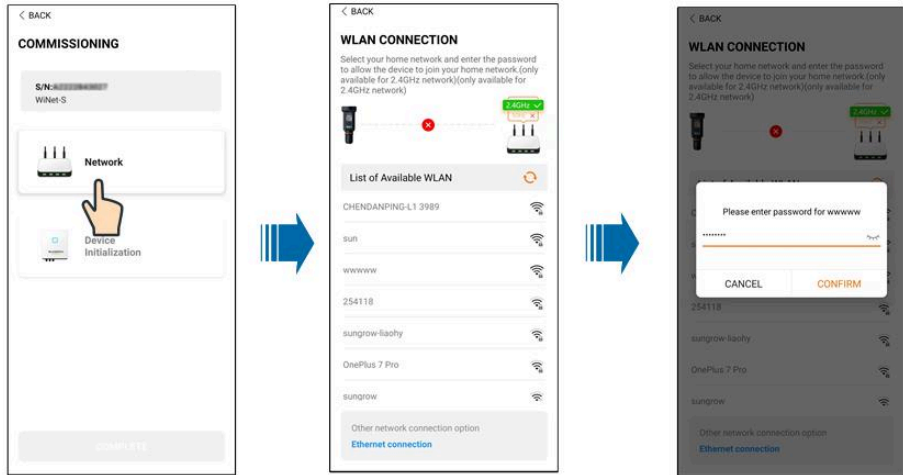
**Step 5** Bind a device through scanning the QR code on the device, manually inputting the device S/N, or uploading a QR code picture. Tap **Confirm** after the QR code is identified or the S/N is verified.



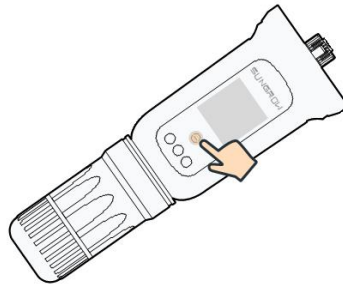
**Step 6** After a device is bound, tap **Device** and **Commissioning** to go to corresponding interface.



**Step 7** Tap **Network Configuration** to go to the **WLAN connection** interface. Tap the home network in the WLAN list, enter the password, and then tap **Confirm**.



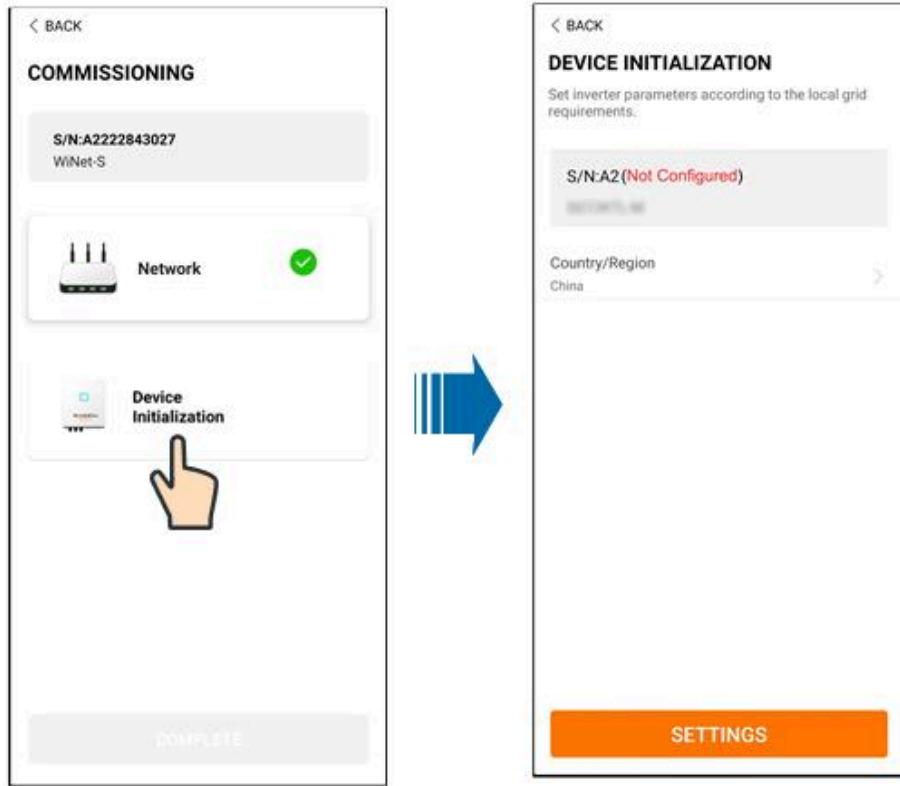
- Step 8** Enter the **Activate EasyConnect** interface, and press the multi-function button on the WiNet-S/WiNet-S2 to enable the Easyconnect mode according to the prompt on the screen. The App automatically enters a waiting processing interface if this mode is enabled, and automatically returns to the commissioning interface after the processing is completed.



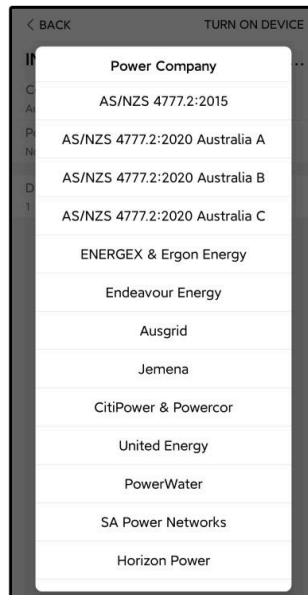
### NOTICE

**Only the 2.4 GHz working band is supported under the networking mode. If the Easyconnect fails, please refer to other methods in the WiNet-S/WiNet-S2 manual to establish the connection.**

- Step 9** Tap **Device Initialization** to go to the **Device initialization** interface. Set the initialization protection parameters as needed and tap **Settings** to return to the commissioning interface.



When the country is set to Australia, additionally set the applicable network service provider and then the grid type.



The image shown here is for reference only. Refer to the actual interface for the supported network service providers.

**Table 6-1** Description of Network Service Provider and Grid Type

Network Service Provider	Grid Type
AS/NZS 4777.2:2015	/
AS/NZS 4777.2:2020 Australia A	/
AS/NZS 4777.2:2020 Australia B	/
AS/NZS 4777.2:2020 Australia C	/
ENERGEX & Ergon Energy	<ul style="list-style-type: none"> <li>• STNW1170: single-phase &lt; 10 kVA &amp; three-phase &lt; 30 kVA</li> <li>• STNW1174: 30 kVA &lt; <math>P_n</math> ≤ 1500 kVA</li> </ul>
Jemena	<ul style="list-style-type: none"> <li>• ≤ 10 kVA per phase (or 30 kVA per three phase)</li> <li>• ELE GU 0014: 30 kVA–200 kVA</li> </ul>
Endeavour Energy	MDI 0043
Ausgrid	NS194
CitiPower & Powercor	<ul style="list-style-type: none"> <li>• ≤ 5 kVA for single-phase &amp; 30 kVA for three-phase</li> <li>• &gt; 30 kVA three-phase</li> </ul>
United Energy	<ul style="list-style-type: none"> <li>• UE-ST-2008.1: ≤ 10 kVA for single-phase &amp; 30 kVA for three-phase</li> <li>• UE-ST-2008.2: &gt; 30 kVA three-phase</li> </ul>
PowerWater	Embedded Generation Notice Photovoltaic Systems:2020
SA Power Networks	<ul style="list-style-type: none"> <li>• TS129-2019: &lt; 10 kW for single-phase &amp; 30 kW for three-phase</li> <li>• TS130-2017: &gt; 30 kW &amp; ≤ 200 kW</li> <li>• TS131-2018: &gt; 200 kW</li> </ul>
Horizon Power	<ul style="list-style-type: none"> <li>• HPC-9DJ-13-0001-2019: ≤ 10kVA for single-phase &amp; 30 kVA for three-phase</li> <li>• HPC-9DJ-13-0002-2019: &gt; 30kVA &amp; ≤1MVA</li> </ul>

Network Service Provider	Grid Type
westernpower	EDM#33612889-2019
AusNet Services	Basic Micro Embedded Generation: 2020

\* For compliance with AS/NZS 4777.2:2020, please select from Australia A/B/C. Please contact your electricity grid operator for which region to use.

- Please check the country supported by this product at <http://support.sungrowpower.com/>.
- Set **Country/Region** to the country/region where the inverter is installed. Otherwise, the inverter may report a fault.

**Step 10** After a plant is successfully created, return to the App home page to view the plant information.

--End

## 6.5 Optimizer Physical Layout (Optional)

- If PV modules are installed and optimizers are configured, check to ensure that all devices are reliably installed.
- Remove QR code labels from the optimizers and attach them to corresponding square cells on the physical layout.
- Please refer to the optimizer user manual for details of the optimizer physical layout.



# 7 iSolarCloud App

## 7.1 About iSolarCloud

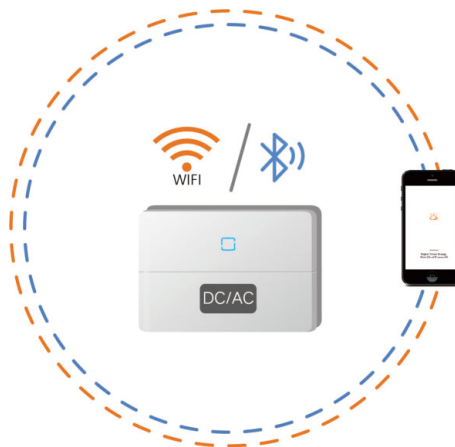
The iSolarCloud App is a mobile application used for power plant management. The App provides plant operation analysis service and enables intelligent mobile O&M. It is designed with functions such as plant operation data display, rapid plant access, parameter setting, quick fault location and notification, and power yield and revenue analysis. With iSolarCloud, convenient and efficient end-to-end plant O&M is allowed.

### Connection Methods

Users can log in to the App via remote connection or local access for plant monitoring.

#### Login by Establishing a Direct Connection (Local)

Establish communication between the mobile phone and the WiFi wireless communication module or the inverter's built-in Bluetooth module to enable mobile maintenance of the inverter. After logging into the App, users can check the information about and set parameters for the inverter.



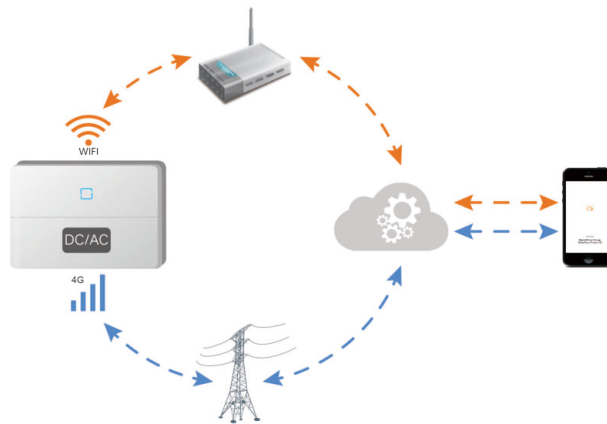
Direct Login (Local)

Login via Bluetooth connection is applicable only for SUNGROW inverters with built-in Bluetooth modules. Please consult your retailer/installer about whether the inverter is equipped with a Bluetooth module.

#### Login with an Account (Remote)

Establish communication between the communication module and the home router or base station to enable data exchange between the inverter and the cloud server. After logging

into the App, users can check the inverter data or send commands to control the inverter on the App.



Login Via Account and Password (Remote)

## 7.2 Install iSolarCloud

### Prerequisite

This section introduces how to download and install the iSolarCloud App.

### Procedure

**Step 1** Search for **iSolarCloud** in App Store, Google Play or other App stores, or scan the QR code below with a mobile phone and download the App by following the onscreen instructions.



**Step 2** Tap the downloaded installation package and follow the onscreen instructions to complete the installation. The icon of iSolarCloud will then appear on the screen.



--End

### 7.3 User Roles

After logging into the iSolarCloud App with different roles, users will have varying levels of access to device operations. The default accounts and passwords corresponding to different user roles can be found in [iSolarCloud App User Manual Device Commissioning \(V2.1.6.20250218or Later\)](#) > **Device Connection** > **Device Connection via WLAN** > **Identity Verification**.

For account security purposes, please refer to the **Identity Verification** section to change your password promptly after logging into the iSolarCloud App.

### 7.4 Device Commissioning

For device commissioning operations, please refer to the **Device Commissioning** in the [iSolarCloud App User Manual](#). Alternatively, you can scan the QR code below to access the **Device Commissioning** section of the manual.



# 8 System Decommissioning

## 8.1 Disconnecting the Inverter

### Prerequisite

#### **⚠ CAUTION**

**Danger of burns!**  
Even if the inverter is shut down, it may still be hot and cause burns. Wear protective gloves before operating the inverter after it cools down.

For maintenance or other service work, the inverter must be switched off. Proceed as follows to disconnect the inverter. Lethal voltages or damage to the inverter will follow if otherwise.

**Step 1** Disconnect the external AC circuit breaker and prevent it from inadvertent reconnection.

**Step 2** Rotate the DC switch to the "OFF" position for disconnecting all of the PV string inputs.

**Step 3**

**Step 4** Wait about 10 minutes until the capacitors inside the inverter completely discharge.

**Step 5** Ensure that the DC cable is current-free with a current clamp.

--End

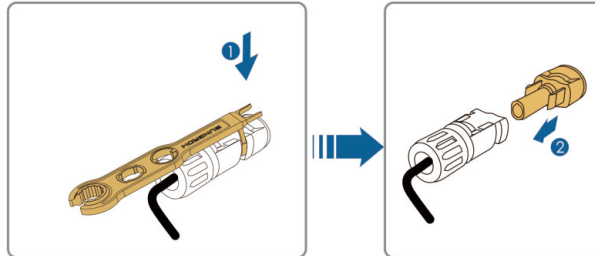
## 8.2 Dismantling the Inverter

#### **⚠ CAUTION**

**Risk of burn injuries and electric shock!**  
After the inverter is powered off for 10 minutes, measure the voltage and current with professional instrument. Only when there is no voltage nor current can operators who wear protective equipment operate and maintain the inverter.

- Before dismantling the inverter, disconnect the inverter from both AC and DC power sources.
- If there are more than two layers of inverter DC terminals, dismantle the outer DC connectors before dismantling the inner ones.
- If the original packing materials are available, put the inverter inside them and then seal them using adhesive tape. If the original packing materials are not available, put the inverter inside a cardboard box suitable for the weight and size of this inverter and seal it properly.

**Step 1** Refer to [5 Electrical Connection](#), for the inverter disconnection of all cables in reverse steps. In particular, when removing the DC connector, use an MC4 wrench to loosen the locking parts and install waterproof plugs.



**Step 2** Refer to [4 Mechanical Mounting](#), to dismantle the inverter in reverse steps.

**Step 3** If necessary, remove the wall-mounting bracket from the wall.

**Step 4** If the inverter will be used again in the future, please refer to [3.2 Inverter Storage](#) for a proper conservation.

--End

## 8.3 Disposal of Inverter

Users take the responsibility for the disposal of the inverter.

### **⚠ WARNING**

**Please scrap the inverter in accordance with relevant local regulations and standards to avoid property losses or casualties.**

### **NOTICE**

**Some parts of the inverter may cause environmental pollution. Please dispose of them in accordance with the disposal regulations for electronic waste applicable at the installation site.**

# 9 Troubleshooting and Maintenance

## 9.1 Troubleshooting

Once the inverter fails, the fault information is displayed on the App interface. If the inverter is equipped with an LCD screen, the fault information can be viewed on it.

The fault codes and troubleshooting methods of all PV inverters are detailed in the table below, and only some of the faults may occur to the model you purchased. When a fault occurs, you can check the fault information according to the fault code on the mobile app.

Fault Code	Fault Name	Corrective Measures
2, 3, 14, 15	Grid Overvoltage	<p>Generally, the inverter will be reconnected to the grid after the grid returns to normal. If the fault occurs repeatedly:</p> <ol style="list-style-type: none"><li>1. Measure the actual grid voltage, and contact the local electric power company for solutions if the grid voltage is higher than the set value.</li><li>2. Check whether the protection parameters are appropriately set via the App or the LCD. Modify the overvoltage protection values with the consent of the local electric power operator.</li><li>3. Contact Sungrow Customer Service if the preceding causes are ruled out and the fault persists.</li></ol>
4, 5	Grid Undervoltage	<p>Generally, the inverter will be reconnected to the grid after the grid returns to normal. If the fault occurs repeatedly:</p> <ol style="list-style-type: none"><li>1. Measure the actual grid voltage, and contact the local electric power company for solutions if the grid voltage is lower than the set value.</li><li>2. Check whether the protection parameters are appropriately set via the App or the LCD.</li><li>3. Check whether the AC cable is firmly in place.</li><li>4. Contact Sungrow Customer Service if the preceding causes are ruled out and the fault persists.</li></ol>

Fault Code	Fault Name	Corrective Measures
8	Grid Overfrequency	<p>Generally, the inverter will be reconnected to the grid after the grid returns to normal. If the fault occurs repeatedly:</p> <ol style="list-style-type: none"> <li>1. Measure the actual grid frequency, and contact the local electric power company for solutions if the grid frequency is beyond the set range.</li> </ol>
9	Grid Underfrequency	<ol style="list-style-type: none"> <li>2. Check whether the protection parameters are appropriately set via the App or the LCD.</li> <li>3. Contact Sungrow Customer Service if the preceding causes are ruled out and the fault persists.</li> </ol>
10	Grid Power Outage	<p>Generally, the inverter will be reconnected to the grid after the grid returns to normal. If the fault occurs repeatedly:</p> <ol style="list-style-type: none"> <li>1. Check whether the grid supplies power reliably.</li> <li>2. Check whether the AC cable is firmly in place.</li> <li>3. Check whether the AC cable is connected to the correct terminal (whether the live wire and the N wire are correctly in place).</li> <li>4. Check whether the AC circuit breaker is connected.</li> <li>5. Contact Sungrow Customer Service if the preceding causes are ruled out and the fault persists.</li> </ol>
12	Excess Leakage Current	<ol style="list-style-type: none"> <li>1. The fault can be caused by poor sunlight or damp environment, and generally the inverter will be reconnected to the grid after the environment is improved.</li> <li>2. If the environment is normal, check whether the AC and DC cables are well insulated.</li> <li>3. Contact Sungrow Customer Service if the preceding causes are ruled out and the fault persists.</li> </ol>
13	Grid Abnormal	<p>Generally, the inverter will be reconnected to the grid after the grid returns to normal. If the fault occurs repeatedly:</p>

Fault Code	Fault Name	Corrective Measures
		<ol style="list-style-type: none"> <li>1. Measure the actual grid, and contact the local electric power company for solutions if the grid parameter exceeds the set range.</li> <li>2. Contact Sungrow Customer Service if the preceding causes are ruled out and the fault persists.</li> </ol>
17	Grid Voltage Imbalance	<p>Generally, the inverter will be reconnected to the grid after the grid returns to normal. If the fault occurs repeatedly:</p> <ol style="list-style-type: none"> <li>1. Measure the actual grid voltage. If grid phase voltages differ greatly, contact the electric power company for solutions.</li> <li>2. If the voltage difference between phases is within the permissible range of the local power company, modify the grid voltage imbalance parameter through the App or the LCD.</li> <li>3. Contact Sungrow Customer Service if the preceding causes are ruled out and the fault persists.</li> </ol>
28, 29, 208, 212, 448-479	PV Reserve Connection Fault	<ol style="list-style-type: none"> <li>1. Check whether the corresponding string is of reverse polarity. If so, disconnect the DC switch and adjust the polarity when the string current drops below 0.5 A.</li> <li>2. Contact Sungrow Customer Service if the preceding causes are ruled out and the fault persists.</li> </ol> <p>*The code 28 to code 29 are corresponding to PV1 to PV2 respectively. *The code 448 to code 479 are corresponding to string 1 to string 32 respectively.</p>
532-547, 564-579	PV Reverse Connection Alarm	<ol style="list-style-type: none"> <li>1. Check whether the corresponding string is of reverse polarity. If so, disconnect the DC switch and adjust the polarity when the string current drops below 0.5 A.</li> <li>2. Contact Sungrow Customer Service if the preceding causes are ruled out and the alarm persists.</li> </ol> <p>*The code 532 to code 547 are corresponding to string 1 to string 16 respectively. *The code 564 to code 579 are corresponding to string 17 to string 32 respectively.</p>

Fault Code	Fault Name	Corrective Measures
548-563, 580-595	PV Abnormal Alarm	<p>Check whether the voltage and current of the inverter is abnormal to determine the cause of the alarm.</p> <ol style="list-style-type: none"> <li>1. Check whether the corresponding module is sheltered. If so, remove the shelter and ensure module cleanness.</li> <li>2. Check whether the battery board wiring is loose, if so, make it reliably connected.</li> <li>3. Check if the DC fuse is damaged. If so, replace the fuse.</li> <li>4. Contact Sungrow Customer Service if the preceding causes are ruled out and the alarm persists.</li> </ol> <p>*The code 548 to code 563 are corresponding to string 1 to string 16 respectively. *The code 580 to code 595 are corresponding to string 17 to string 32 respectively.</p>
37	Excessively High Ambient Temperature	<p>Generally, the inverter will resume operation when the internal or module temperature returns to normal. If the fault persists:</p> <ol style="list-style-type: none"> <li>1. Check whether the ambient temperature of the inverter is too high;</li> <li>2. Check whether the inverter is in a well-ventilated place;</li> <li>3. Check whether the inverter is exposed to direct sunlight. Shield it if so;</li> <li>4. Check whether the fan is running properly. Replace the fan if not;</li> <li>5. Contact Sungrow Power Customer Service if the fault is due to other causes and the fault persists.</li> </ol>
43	Excessively Low Ambient Temperature	<p>Stop and disconnect the inverter. Restart the inverter when the ambient temperature rises within the operation temperature range.</p>
39	Low System Insulation Resistance	<p>Wait for the inverter to return to normal. If the fault occurs repeatedly:</p> <ol style="list-style-type: none"> <li>1. Check whether the ISO resistance protection value is excessively high via the app or the LCD, and ensure that it complies with the local regulations.</li> </ol>

Fault Code	Fault Name	Corrective Measures
		<ol style="list-style-type: none"> <li>2. Check the resistance to ground of the string and DC cable. Take corrective measures in case of short circuit or damaged insulation layer.</li> <li>3. If the cable is normal and the fault occurs on rainy days, check it again when the weather turns fine.</li> <li>4. If there are batteries, check whether battery cables are damaged and whether terminals are loose or in poor contact. If so, replace the damaged cable and secure terminals to ensure a reliable connection.</li> <li>5. Contact Sungrow Customer Service if the preceding causes are ruled out and the fault persists.</li> </ol>
106	Grounding Cable Fault	<ol style="list-style-type: none"> <li>1. Check whether the AC cable is correctly connected.</li> <li>2. Check whether the insulation between the ground cable and the live wire is normal.</li> <li>3. Contact Sungrow Customer Service if the preceding causes are ruled out and the fault persists.</li> </ol>
88	Electric Arc Fault	<ol style="list-style-type: none"> <li>1. Disconnect the DC power supply, and check whether any DC cable is damaged, the connection terminal or fuse is loose or there is a weak contact. If so, replace the damaged cable, fasten the terminal or fuse, and replace the burnt component.</li> <li>2. After performing step 1, reconnect the DC power supply, and clear the electric arc fault via the App or the LCD, after that the inverter will return to normal.</li> <li>3. Contact Sungrow Customer Service if the fault persists.</li> </ol>
84	Reverse Connection Alarm of the Meter/CT	<ol style="list-style-type: none"> <li>1. Check if the meter is wrongly connected.</li> <li>2. Check if the input and output wiring of the meter is reversed.</li> <li>3. If the existing system is enabled, please check if the rated power setting of the existing inverter is correct.</li> </ol>

Fault Code	Fault Name	Corrective Measures
514	Meter Communication Abnormal Alarm	<ol style="list-style-type: none"> <li>1. Check whether the communication cable and the terminals are abnormal. If so, correct them to ensure reliable connection.</li> <li>2. Reconnect the communication cable of the meter.</li> <li>3. Contact Sungrow Customer Service if the preceding causes are ruled out and the alarm persists.</li> </ol>
323	Grid Confrontation	<ol style="list-style-type: none"> <li>1. Check whether the output port is connected to actual grid. Disconnect it from the grid if so.</li> <li>2. Contact Sungrow Customer Service if the preceding causes are ruled out and the fault persists.</li> </ol>
75	Inverter Parallel Communication Alarm	<ol style="list-style-type: none"> <li>1. Check whether the communication cable and the terminals are abnormal. If so, correct them to ensure reliable connection.</li> <li>2. Reconnect the communication cable of the meter.</li> <li>3. Contact Sungrow Customer Service if the preceding causes are ruled out and the alarm persists.</li> </ol>
7, 11, 16, 19–25, 30–34, 36, 38, 40–42, 44–50, 52–58, 60–69, 85, 87, 92, 93, 100–105, 107–114, 116–124, 200–211, 248–255, 300–322, 324–328, 401–412, 600–603, 605, 608, 612, 616, 620, 622–624, 800, 802, 804,	System Fault	<ol style="list-style-type: none"> <li>1. Wait for the inverter to return to normal.</li> <li>2. Disconnect the AC and DC switches, and disconnect the battery side switches if there are batteries. Close the AC and DC switches in turn 15 minutes later and restart the system.</li> <li>3. Contact Sungrow Customer Service if the preceding causes are ruled out and the fault persists.</li> </ol>

Fault Code	Fault Name	Corrective Measures
807, 1096–1118		
59, 70–74, 76–83, 89, 216–218, 220–233, 432–434, 500–513, 515–518, 635–638, 900, 901, 910, 911, 996	System Alarm	<ol style="list-style-type: none"> <li>1. The inverter can continue running.</li> <li>2. Check whether the related wiring and terminal are abnormal, check whether there are any foreign materials or other environmental abnormalities, and take corresponding corrective measures when necessary.</li> <li>3. If the fault persists, please contact Sungrow Power Customer Service.</li> </ol>
264-283	MPPT Reverse Connection	<ol style="list-style-type: none"> <li>1. Check whether the corresponding string is of reverse polarity. If so, disconnect the DC switch and adjust the polarity when the string current drops below 0.5 A.</li> <li>2. Contact Sungrow Customer Service if the preceding causes are ruled out and the fault persists.</li> </ol> <p>*The code 264 to code 279 are corresponding to string 1 to string 20 respectively.</p>
332-363	Boost Capacitor Overvoltage Alarm	<ol style="list-style-type: none"> <li>1. The inverter can continue running.</li> <li>2. Check whether the related wiring and terminals are abnormal, check whether there are any foreign materials or other environmental abnormalities, and take corresponding corrective measures when necessary.</li> </ol> <p>If the fault persists, please contact Sungrow Power Customer Service.</p>
364-395	Boost Capacitor Overvoltage Fault	<ol style="list-style-type: none"> <li>1. Disconnect the AC and DC switches, and disconnect the battery side switches if there are batteries. Close the AC and DC switches in turn 15 minutes later and restart the system.</li> <li>2. If the fault persists, please contact Sungrow Power Customer Service.</li> </ol>
1548-1579	String Current Reflux	<ol style="list-style-type: none"> <li>1. Check whether the number of PV modules of the corresponding string is less than other strings. If so, disconnect the DC switch and</li> </ol>

Fault Code	Fault Name	Corrective Measures
		<p>adjust the PV module configuration when the string current drops below 0.5 A.</p> <p>2. Check whether the PV module is shaded;</p> <p>3. Disconnect the DC switch to check whether the open circuit voltage is normal when the string current drops below 0.5 A. If so, check the wiring and configuration of the PV module,</p> <p>4. Check whether the orientation of the PV module is abnormal.</p>
1600 - 1615, 1632 - 1655	PV Grounding Fault	<p>1. When the fault occurs, it is forbidden to directly disconnect the DC switch and unplug PV terminals when the direct current is greater than 0.5 A;</p> <p>2. Wait until the direct current of the inverter falls below 0.5 A, then disconnect the DC switch and unplug the faulty strings;</p> <p>3. Do not reinsert the faulty strings before the grounding fault is cleared;</p> <p>4. If the fault is not caused by the foregoing reasons and still exists, contact Sungrow Customer Service.</p>
1616	System Hardware Fault	<p>1. It is prohibited to disconnect the DC switch when the DC current is greater than 0.5 A when the fault occurs.</p> <p>2. Disconnect the DC switch only when the inverter DC side current drops below 0.5 A.</p> <p>3. It is prohibited to power up the inverter again. Please contact Sungrow Customer Service.</p>

Once a fault occurs to the optimizer, the fault information is displayed on the App.

Fault Code	Fault Name	Possible Cause	Corrective Method
4	Input overvolt age	The PV voltage is higher than the set protectio n value	Check whether the open-circuit voltage of the PV module connected to the optimizer exceeds the maximum input voltage allowed by the optimizer.

Fault Code	Fault Name	Possible Cause	Corrective Method
512	Hardware fault	A hardware fault occurs to the optimizer	Please contact Sungrow Customer Service.
1024	Update failed	The optimizer software fails to upgrade	<ol style="list-style-type: none"> <li>1. The software upgrade may take more than 20 minutes for a large-scale system with a great number of optimizers. Please check the light condition, and perform the software upgrade under good light conditions.</li> <li>2. If the fault persists, please contact Sungrow Customer Service.</li> </ol>

- If there is a string current backfeed fault, first check whether the optimizer is offline.
- Contact the dealer if the measures listed in the “Troubleshooting Method” column have been taken but the problem persists. Contact SUNGROW if the dealer fails to solve the problem.

## 9.2 Maintenance

### 9.2.1 Maintenance Notices

The DC switch can be secured with a lock in the OFF position or a certain angle beyond the OFF position.(For countries “AU” and “NZ”)

**⚠ DANGER**

**Risk of inverter damage or personal injury due to incorrect service!**

- Be sure to use special insulation tools when perform high-voltage operations.
- Before any service work, first disconnect the grid-side AC circuit breaker and check the inverter status. If the inverter indicator is off, please wait until night to disconnect the DC switch. If the inverter indicator is on, directly disconnect the DC switch.
- After the inverter is powered off for 10 minutes, measure the voltage and current with professional instrument. Only when there is no voltage nor current can operators who wear protective equipment operate and maintain the inverter
- Even if the inverter is shut down, it may still be hot and cause burns. Wear protective gloves before operating the inverter after it cools down.
- When maintaining the product, it is strictly prohibited to open the product if there is an odor or smoke or if the product appearance is abnormal. If there is no odor, smoke, or obvious abnormal appearance, repair or restart the inverter according to the alarm corrective measures. Avoid standing directly in front of the inverter during maintenance.

**⚠ CAUTION**

To prevent misuse or accidents caused by unrelated personnel: Post prominent warning signs or demarcate safety warning areas around the inverter to prevent accidents caused by misuse.

**NOTICE**

Restart the inverter only after removing the fault that impairs safety performance. As the inverter contains no component parts that can be maintained, never open the enclosure, or replace any internal components.

To avoid the risk of electric shock, do not perform any other maintenance operations beyond those described in this manual. If necessary, contact your distributor first. If the problem persists, contact SUNGROW. Otherwise, the losses caused is not covered by the warranty.

**NOTICE**

Touching the PCB or other static sensitive components may cause damage to the device.

- Do not touch the circuit board unnecessarily.
- Observe the regulations to protect against electrostatic and wear an anti-static wrist strap.

### 9.2.2 Quick Shutdown

The PV system can perform a quick shutdown, reducing the output voltage of strings to below 30 V within 20 s.

Triggering methods of quick shutdown:

- Method 1: Turn off the AC circuit breaker between the inverter and the grid.
- Method 2: Connect RSD-1 and RSD-2 in COM2 port to trigger quick shutdown. Disconnect RSD-1 and RSD-2 to exit the quick shutdown mode.

#### NOTICE

- **The quick shutdown is not supported if optimizers are configured for some PV modules.**
- **Please check regularly whether the quick shutdown function is normal.**

### 9.2.3 Routine Maintenance

Item	Method	Period
Device clean	Check the temperature and dust of the device. Clean the device enclosure if necessary.	Six months to a year (depending on the dust contents in air)
Electrical connection	Check whether all cable are firmly connected in place. Check whether there is damage to the cables, especially the surface in contact with metal.	6 months after commissioning and then once or twice a year
General status of the system	<ul style="list-style-type: none"> <li>• Visual check for any damage or deformation of the microinverter.</li> <li>• Check any abnormal noise during the operation.</li> <li>• Check each operation parameter.</li> <li>• Be sure that nothing covers the heat sink of the device.</li> </ul>	Every 6 months

### 9.2.4 Fan Maintenance

#### Prerequisite

If the inverter has an external fan, when the fan fails to work normally, the inverter cannot be effectively cooled, which will affect the efficiency of the inverter or cause derated operation. Therefore, keep the fan clean and replace the damaged fan in time.

**⚠ WARNING**

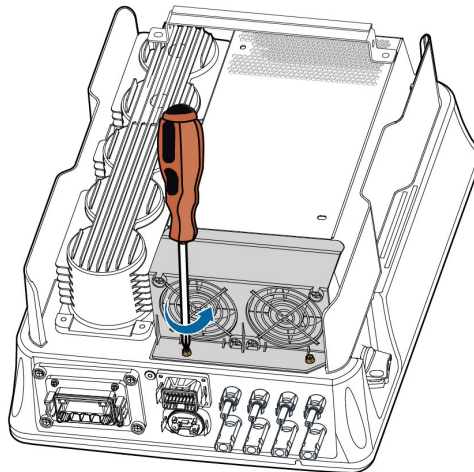
- **Power off the inverter and disconnect it from all power supplies before maintaining fans.**
- **After the inverter is powered off for 10 minutes, measure the voltage and current with professional instrument. Only when there is no voltage nor current can operators who wear protective equipment operate and maintain the inverter.**
- **Fan maintenance must be performed by professionals.**

**Step 1** Refer to [8.1 Disconnecting the Inverter](#) to stop the inverter.

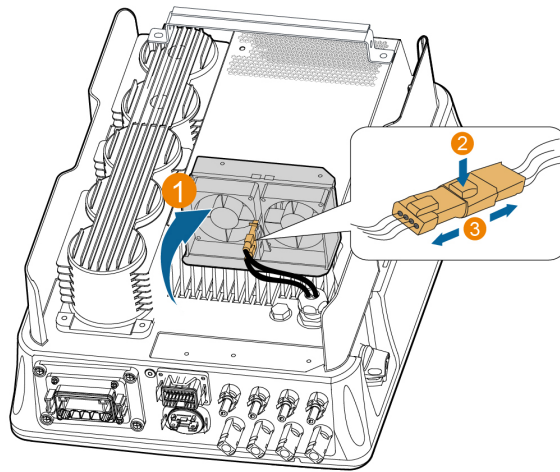
**Step 2** Refer to [5 Electrical Connection](#) and disconnect all the cable connections in reverse steps.

**Step 3** Refer to [4 Mechanical Mounting](#) and dismantle the inverter in reverse steps.

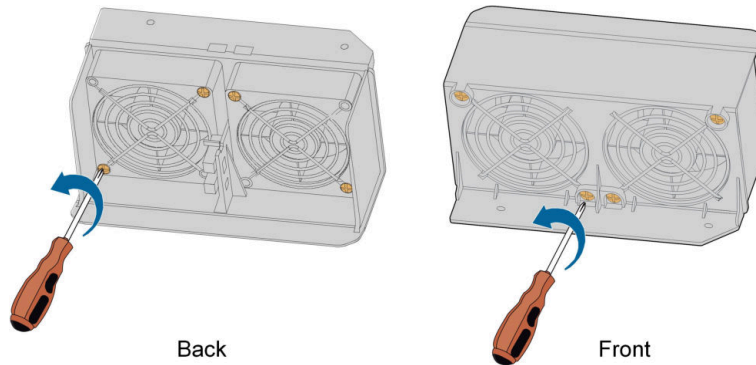
**Step 4** Unscrew the screws on the fan bracket.



**Step 5** Lift the fan bracket upwards, press down the protrusion on the fan power plug connector and pull it outwards, and remove the fan bracket.



**Step 6** Unscrew the screws on the dust covers and remove the dust covers.



**Step 7** Use a soft brush or vacuum cleaner to clean the fan. If you need to replace the fan, use a screwdriver to unscrew the screw at the fan bracket and remove the fan.

**Step 8** Install the dust covers and then the fan bracket to the inverter. Restart the inverter.

**--End**

# 10 Appendix

## 10.1 Technical Data

Parameter	SG3.0RT	SG4.0RT
<b>Input (DC)</b>		
Recommended max. PV input power	4.5 kWp	6.0 kWp
Max. PV input voltage <sup>(3)</sup>	1100 V <sup>(1)</sup>	
Min. PV input voltage / Start-up input voltage	180V / 180V	
Rated PV input voltage	600 V	
MPPT operating voltage range <sup>(4)</sup>	160 V–1000 V <sup>(2)</sup>	
MPPT voltage range for rated power	160V-850V <sup>(5)</sup>	
No. of independent MPP inputs	2	
No. of PV strings per MPPT	1 / 1	
Max. PV input current	25 A (12.5 A / 12.5 A)	
Max. DC short-circuit current	32 A (16 A / 16 A)	
Max. current for DC connector	30A	
<b>Output (AC)</b>		
Rated AC output power	3000 W	4000 W
Max. AC output apparent power	3300VA	4400VA
Max. AC output current	5.1A	6.8A

Parameter	SG3.0RT	SG4.0RT
Rated AC voltage		3 / N / PE, 220 V / 380 V
		3 / N / PE, 230 V / 400 V
		3 / N / PE, 240 V / 415 V
AC voltage range	180 V–276 V / 311 V–478 V	
Rated grid frequency	50 Hz / 60 Hz	
Grid frequency range	45 Hz–55 Hz / 55 Hz–65 Hz	
Harmonic (THD)	< 5 % (at rated power)	
Power factor at Rated power / Adjustable power factor	> 0.99 / 0.8 leading - 0.8 lagging	
Feed-in phases / connection phases	3 / 3-PE	
<b>Efficiency</b>		
Max. efficiency	98.20 %	
European efficiency	96.50 %	97.00 %
<b>Protection &amp; Function</b>		
Grid monitoring	Yes	
DC reverse connection protection	Yes	
AC short-circuit protection	Yes	
Leakage current protection	Yes	
Surge Protection	DC Type II / AC Type II	
Ground fault monitoring	Yes	
DC switch	Yes	
PV String current monitoring	Yes	

Parameter	SG3.0RT	SG4.0RT
Arc fault circuit interrupter (AFCI)		Yes
PID recovery function		Yes
Protective Class		I
Overvoltage Category		DC II/AC III
Active Anti-Islanding Method		Frequency Shift
<b>General Data</b>		
Dimensions (W x H x D)	370 mm x 480 mm x 195 mm	
Weight	18 kg	
Mounting method	Wall-mounting bracket	
Topology	Transformerless	
Degree of protection	IP65	
Night power consumption	< 6W	
Corrosion	C5	
Operating ambient temperature range	-25°C to +60°C	
Allowable relative humidity range (non-condensing)	0–100 %	
Cooling method	Natural cooling	
Max. operating altitude	4000 m	
Display	LED	
Communication	WLAN / Ethernet / RS485 / DI / DO	
DC connection type	MC4 (Max. 6 mm <sup>2</sup> )	
AC connection type	Plug and play	
Grid Compliance	IEC / EN 61000-6-1/2/3/4, IEC / EN62109-1/2, IEC 61727 □ IEC 62116, IEC 61683, EN50530, EN50549-1	

Parameter	SG3.0RT	SG4.0RT
Grid Support	LVRT, HVRT, active & reactive power control and power ramp rate control	

(1) The inverter enters standby state when the input voltage ranges between 1,000 V and 1,100 V. If the maximum DC voltage in the system can exceed 1,000 V, the MC4 connectors included in the scope of delivery must not be used. In this case MC4-Evo2 connectors must be used.

(2) Please note the min. voltage without MPP tracker derating is 303V (+5%) for SG10/15/20RT and 236V(+5%) for SG5.0/7.0/8.0RT @AC230V 12.5A.

(3) Input voltage exceeding the MPPT operating voltage range triggers inverter protection.

(4) Please refer to the user manual for the full load MPPT voltage range.

(5) The "MPPT Voltage Range for Rated Power" for the MENA region can be found in the TI document. Please contact Sungrow for further details.

Parameter	SG5.0RT	SG6.0RT
<b>Input (DC)</b>		
Recommended max. PV input power	7.5 kWp	9.0 kWp
Max. PV input voltage <sup>(3)</sup>	1100 V <sup>(1)</sup>	
Min. PV input voltage / Start-up input voltage	180 V / 180 V	
Rated input voltage	600 V	
MPPT operating voltage range <sup>(4)</sup>	160 V–1000 V <sup>(2)</sup>	
MPPT voltage range for rated power	260V-850V <sup>(5)</sup>	320V - 850V <sup>(5)</sup>
No. of independent MPP inputs	2	
No. of of PV strings per MPPT	1 / 1	
Max. PV input current	32 A (16 A / 16 A) for "AU", 25 A (12.5 A / 12.5 A) for others	

Parameter	SG5.0RT	SG6.0RT
Max. DC short-circuit current	45 A (22.5 A / 22.5 A) for "AU", 32 A (16 A / 16 A) for others	
Max. current for DC connector	30 A	
<b>Output (AC)</b>		
Rated AC power	5000 W	6000 W
Max. AC output apparent power	5000 VA for "AU", "BE", "DE", 5500 VA for others	6000 VA for "AU", "BE", "DE", 6600 VA for others
Rated AC output apparent power	5000 VA for "AU", "BE", "DE", 5500 VA for others	6000 VA for "AU", "BE", "DE", 6600 VA for others
Max. AC output current	7.6 A for "AU", 8.3 A for others	7.6 A for "AU", 8.3 A for others
Rated AC output current(at 230V)	7.2 A	8.7 A
Rated AC voltage	3/N/PE, 220 V/380 V 3/N/PE, 230 V/400 V(for "AU") 3/N/PE, 240 V/415 V	
AC voltage range	180 V–276 V / 311 V–478 V	
Rated grid frequency	50 Hz / 60 Hz	
Grid frequency range	45 Hz–55 Hz / 55 Hz–65 Hz	
Harmonic (THD)	< 3 % (at rated power)	
Power factor at nominal power / Adjustable power factor	> 0.99 / 0.8 leading – 0.8 lagging	
Feed-in phases / connection phases	3 / 3–PE	
<b>Efficiency</b>		
Max. efficiency	98.40 %	
European efficiency	97.40 %	
<b>Protection &amp; Function</b>		

Parameter	SG5.0RT	SG6.0RT
Grid monitoring		Yes
DC reverse connection protection		Yes
AC short-circuit protection		Yes
Leakage current protection		Yes
Surge Protection		DC Type II / AC Type II
Ground fault monitoring		Yes
DC switch		Yes
PV String current monitoring		Yes
Arc fault circuit interrupter (AFCI)		optional
PID recovery function		Yes
Protective Class		I
Oversoltage Category		DC II/AC III
Active Anti-Islanding Method		Frequency Shift
<b>General Data</b>		
Dimensions (W x H x D)	370 mm x 480 mm x 195 mm	
Weight	18 kg	
Mounting method	Wall-mounting bracket	
Topology	Transformerless	
Degree of protection	IP65	
Night power consumption	<6W	
Corrosion	C5	
Operating ambient temperature range	-25°C to +60°C(AU: Derating when the temperature exceeds 40°C)	

Parameter	SG5.0RT	SG6.0RT
Allowable relative humidity range (non-condensing)		0–100 %
Cooling method		Natural cooling
Max. operating altitude		4000 m
Display		LED
Communication		WLAN / Ethernet / RS485 / DI / DO
DC connection type		MC4 (Max. 6 mm <sup>2</sup> )
AC connection type		Plug and play
Grid Compliance	IEC / EN 61000-6-1/2/3/4, IEC 61000-3-2/3/11/12, IEC / EN62109-1/2, IEC 61727, IEC 62116, IEC 61683, IEC 60068-2-1/2/14/30/64/27, IEC TS 62910, EN50530, AS/NZS 4777.2:2020, VDE-AR-N-4105, DIN VDE0126-1-1/A1, EN50549-1, DEWA, VFR 2019, UTE C15-712-1, PSE NC RfG, UNE 206006/7 IN, MEA/PEA, G98, UNE 217002:2020, NTS V2 TypeA	
Compliance(AU)	IEC 62109-1/2, AS/NZS 4777.2:2020	
Grid Support	LVRT, HVRT, active & reactive power control and power ramp rate control	
Country of manufacture(AU)	China	

(1) The inverter enters standby state when the input voltage ranges between 1,000 V and 1,100 V. If the maximum DC voltage in the system can exceed 1,000 V, the MC4 connectors included in the scope of delivery must not be used. In this case MC4-Evo2 connectors must be used.

(2) Please note the min. voltage without MPP tracker derating is 303V (+5%) for SG10/15/20RT and 236V(+5%) for SG5.0/7.0/8.0RT @AC230V 12.5A.

(3) Input voltage exceeding the MPPT operating voltage range triggers inverter protection.

(4) Please refer to the user manual for the full load MPPT voltage range.

(5) The “MPPT Voltage Range for Rated Power” for the MENA region can be found in the TI document. Please contact Sungrow for further details.

Parameter	SG7.0RT	SG8.0RT
<b>Input (DC)</b>		
Recommended max. PV input power	10.5 kWp	12 kWp
Max. PV input voltage <sup>(3)</sup>	1100 V <sup>(1)</sup>	
Min. PV input voltage / Start-up input voltage	180 V / 180 V	
Rated input voltage	600 V	
MPPT operating voltage range <sup>(4)</sup>	160 V–1000 V <sup>(2)</sup>	
MPPT voltage range for rated power	260V-850V <sup>(5)</sup>	310V - 850V <sup>(5)</sup>
No. of independent MPP inputs	2	
No. of PV strings per MPPT	2 / 1	
Max. PV input current	48 A (32 A / 16 A) for "AU", 37.5 A (25 A / 12.5 A) for others	
Max. DC short-circuit current	67.5 A (45 A / 22.5 A) for "AU", 48 A (32 A / 16 A) for others	
Max. current for DC connector	30 A	
<b>Output (AC)</b>		
Nominal AC power (@ 230 V, 50 Hz)	6999 W for "AU", 7000 W for others	8000 W
Max. AC output power	6999 VA for "AU", 7000 VA for "BE", "DE", 7700 VA for others	8000 VA for "AU", "BE", "DE", 8800 VA for others
Rated AC output apparent power	6999 VA for "AU", 7000 VA for "BE", "DE", 7700 VA for others	8000 VA for "AU", "BE", "DE", 8800 VA for others
Max. AC output current	10.6 A for "AU", 11.7 A for others	12.1A for "AU", 13.3 A for others

Parameter	SG7.0RT	SG8.0RT
Rated AC output current(at 230V)	10.1 A	11.6 A
	3 / N / PE, 220 V / 380 V	
Rated AC voltage	3 / N / PE, 230 V / 400 V (for "AU")	
	3 / N / PE, 240 V / 415 V	
AC voltage range	180 V–276 V / 311 V–478 V	
Rated grid frequency	50 Hz / 60 Hz	
Grid frequency range	45 Hz–55 Hz / 55 Hz–65 Hz	
Harmonic (THD)	< 3 % (at rated power)	
Power factor at Rated power / Adjustable power factor	> 0.99 / 0.8 leading – 0.8 lagging	
Feed-in phases / connection phases	3 / 3–PE	
<b>Efficiency</b>		
Max. efficiency	98.40 %	98.50 %
European efficiency	97.70 %	97.80 %
<b>Protection &amp; Function</b>		
Grid monitoring	Yes	
DC reverse connection protection	Yes	
AC short-circuit protection	Yes	
Leakage current protection	Yes	
Surge Protection	DC Type II / AC Type II	
Ground fault monitoring	Yes	
DC switch	optional <sup>(3)</sup>	
PV String current monitoring	Yes	

Parameter	SG7.0RT	SG8.0RT
Arc fault circuit interrupter (AFCI)		optional
PID recovery function		Yes
Protective Class		I
Overvoltage Category		DC II/AC III
Active Anti-Islanding Method		Frequency Shift
<b>General Data</b>		
Dimensions (W x H x D)	370 mm x 480 mm x 195 mm	
Weight	18 kg	
Mounting method	Wall-mounting bracket	
Topology	Transformerless	
Degree of protection	IP65	
Night power consumption	<6W	
Corrosion	C5	
Operating ambient temperature range	-25°C to +60°C(AU: Derating when the temperature exceeds 40°C)	
Allowable relative humidity range (non-condensing)	0–100 %	
Cooling method	Natural cooling	
Max. operating altitude	4000 m	
Display	LED	
Communication	WLAN / Ethernet / RS485 / DI / DO	
DC connection type	MC4 (Max. 6 mm <sup>2</sup> )	
AC connection type	Plug and play	
Grid Compliance	IEC / EN 61000-6-1/2/3/4, IEC 61000-3-2/3/11/12, IEC / EN62109-1/2, IEC 61727, IEC 62116, IEC 61683, IEC 60068-2-1/2/14/30/64/27, IEC TS 62910 ,	

Parameter	SG7.0RT	SG8.0RT
	EN50530, AS/NZS 4777.2:2020, VDE-AR-N-4105, DIN VDE0126-1-1/A1, EN50549-1, DEWA, VFR 2019, UTE C15-712-1, PSE NC RfG, UNE 206006/7 IN, MEA/PEA, G98, UNE 217002:2020, NTS V2 TypeA	
Compliance(AU)	IEC 62109-1/2, AS/NZS 4777.2:2020	
Grid Support	LVRT, HVRT, active & reactive power control and power ramp rate control	
Country of manufacture(AU)	China	

(1) The inverter enters standby state when the input voltage ranges between 1,000 V and 1,100 V. If the maximum DC voltage in the system can exceed 1,000 V, the MC4 connectors included in the scope of delivery must not be used. In this case MC4-Evo2 connectors must be used.

(2) Please note the min. voltage without MPP tracker derating is 303V (+5%) for SG10/15/20RT and 236V(+5%) for SG5.0/7.0/8.0RT @AC230V 12.5A.

(3) Input voltage exceeding the MPPT operating voltage range triggers inverter protection.

(4) Please refer to the user manual for the full load MPPT voltage range.

(5) The "MPPT Voltage Range for Rated Power" for the MENA region can be found in the TI document. Please contact Sungrow for further details.

Parameter	SG10RT	SG12RT
<b>Input (DC)</b>		
Recommended max. PV input power	15.0 kWp	18.0 kWp
Max. PV input voltage <sup>(3)</sup>	1100 V <sup>(1)</sup>	
Min. PV input voltage / Start-up input voltage	180 V / 180 V	
Rated input voltage	600 V	
MPPT operating voltage range <sup>(4)</sup>	160 V–1000 V <sup>(2)</sup>	
MPPT voltage range for rated power	320 V – 850 V <sup>(5)</sup>	400 V – 850 V <sup>(5)</sup>

Parameter	SG10RT	SG12RT
No. of independent MPP inputs		2
No. of PV strings per MPPT		2 / 1
Max. PV input current	48 A (32 A / 16 A) for "AU" , 37.5 A (25 A / 12.5 A) for others	
Max. DC short-circuit current	67.5 A (45 A / 22.5 A) for "AU" , 48 A (32 A / 16 A) for others	
Max. current for DC connector	30 A	
<b>Output (AC)</b>		
Rated AC power	9999 W for "AU", 10000 W for others	12000 W
Max. AC output apparent power	10000 VA "BE", "DE", 9999 VA for "AU", 11000 VA for others	12000 VA for "AU", "BE", "DE", 13200 VA for others
Rated AC output apparent power	10000 VA for "BE", "DE", 9999 VA for "AU", 11000 VA for others	12000 VA for "AU", "BE", "DE", 13200 VA for others
Max. AC output current	15.2 A for "AU", 16 A for "JO" □ 16.7 A for others	18.2 A for "AU", 20.0 A for others
Rated AC output current(at 230V)	14.5 A	17.4 A
Rated AC voltage	3 / N / PE, 220 V / 380 V	
	3 / N / PE, 230 V / 400 V (for "AU")	
	3 / N / PE, 240 V / 415 V	
AC voltage range	180 V–276 V / 311 V–478 V	
Rated grid frequency	50 Hz / 60 Hz	
Grid frequency range	45 Hz–55 Hz / 55 Hz–65 Hz	
Harmonic (THD)	< 3 % (at rated power)	

Parameter	SG10RT	SG12RT
Power factor at Rated power / Adjustable power factor	> 0.99 / 0.8 leading–0.8 lagging	
Feed-in phases / Connection phases	3 / 3–PE	
<b>Efficiency</b>		
Max. efficiency	98.50 %	
European efficiency	97.90 %	
<b>Protection &amp; Function</b>		
Grid monitoring	Yes	
DC reverse connection protection	Yes	
AC short circuit protection	Yes	
Leakage current protection	Yes	
Surge Protection	DC Type II / AC Type II	
Ground fault monitoring	Yes	
DC switch	Yes	
PV String current monitoring	Yes	
Arc fault circuit interrupter (AFCI)	optional	
PID recovery function	Yes	
Protective Class	I	
Oversoltage Category	DC II/AC III	
Active Anti-Islanding Method	Frequency Shift	
<b>General Data</b>		
Dimensions (W x H x D)	370 mm x 480 mm x 195 mm	

Parameter	SG10RT	SG12RT
Weight		18 kg
Mounting method		Wall-mounting bracket
Topology		Transformerless
Degree of protection		IP65
Night power consumption		<6W
Corrosion		C5
Operating ambient temperature range	-25°C to +60°C(AU: Derating when the temperature exceeds 40°C)	
Allowable relative humidity range (non-condensing)		0–100 %
Max. operating altitude		4000 m
Cooling method		Natural cooling
Display		LED
Communication	WLAN / Ethernet / RS485 / DI / DO	
DC connection type	MC4 (Max. 6 mm <sup>2</sup> )	
AC connection type	Plug and play	
Grid Compliance	IEC / EN 61000-6-1/2/3/4, IEC 61000-3-2/3/11/12, IEC / EN62109-1/2, IEC 61727, IEC 62116, IEC 61683, IEC 60068-2-1/2/14/30/64/27, IEC TS 62910 , EN50530, AS/NZS 4777.2:2020, VDE-AR-N-4105, DIN VDE0126-1-1/A1, EN50549-1, DEWA, VFR 2019, UTE C15-712-1, PSE NC RfG, UNE 206006/7 IN, MEA/PEA, G98, UNE 217002:2020, NTS V2 TypeA	
Compliance(AU)	IEC 62109-1/2, AS/NZS 4777.2:2020	
Grid Support	LVRT, HVRT, active & reactive power control and power ramp rate control	
Country of manufacture	China	

(1) The inverter enters standby state when the input voltage ranges between 1,000 V and 1,100 V. If the maximum DC voltage in the system can exceed 1,000 V, the MC4

connectors included in the scope of delivery must not be used. In this case MC4-Evo2 connectors must be used.

(2) Please note the min. voltage without MPP tracker derating is 303V (+5%) for SG10/15/20RT and 236V(+5%) for SG5.0/7.0/8.0RT @AC230V 12.5A.

(3) Input voltage exceeding the MPPT operating voltage range triggers inverter protection.

(4) Please refer to the user manual for the full load MPPT voltage range.

(5) The“MPPT Voltage Range for Rated Power” for the MENA region can be found in the TI document. Please contact Sungrow for further details.

Parameter	SG15RT	SG17RT	SG20RT
<b>Input (DC)</b>			
Recommended max. PV input power	22.5 kWp	25.5 kWp	30.0 kWp
Max. PV input voltage <sup>(3)</sup>	1100 V <sup>(1)</sup>		
Min. PV input voltage / Start-up input voltage	180 V / 180 V		
Rated input voltage	600 V		
MPPT operating voltage range <sup>(4)</sup>	160 V–1000 V <sup>(2)</sup>		
MPPT voltage range for rated power	380V – 850V <sup>(6)</sup>	365V – 850V <sup>(6)</sup>	430V – 850V <sup>(6)</sup>
No. of independent MPP inputs	2		
No. of PV strings per MPPT	2 / 2		
Max. PV input current	64 A (32 A / 32 A) for "AU" , 50 A (25 A / 25 A) for others		
Max. DC short-circuit current	90 A (45 A / 45 A) for "AU", 64 A (32 A / 32 A) for others		
Max. current for DC connector	30 A		
<b>Output (AC)</b>			
Rated AC power	15000 W	17000 W	20000 W

Parameter	SG15RT	SG17RT	SG20RT
Max. AC output apparent power	15000 VA for "AU", "BE", "DE", 16500 VA for others	17000 VA for "AU", "BE", "DE", 18700 VA for others	20000 VA for "AU", "BE", "DE", 22000 VA for others
Rated AC output apparent power	15000 VA for "AU", "BE", "DE", 16500 VA for others	17000 VA for "AU", "BE", "DE", 18700 VA for others	20000 VA for "AU", "BE", "DE", 22000 VA for others
Max. AC output current	22.7 A for "AU", 25 A for others	25.8 A for "AU", 28.3 A for others	30.3 A for "AU", 31.9 A for others
Rated AC output current(at 230V)	21.7 A	24.6 A	29 A
Rated AC voltage	3 / N / PE, 220 V / 380 V		
	3 / N / PE, 230 V / 400 V (for "AU")		
	3 / N / PE, 240 V / 415 V		
AC voltage range	180 V–276 V / 311 V–478 V		
Rated grid frequency	50 Hz / 60 Hz		
Grid frequency range	45 Hz–55 Hz / 55 Hz–65 Hz		
Harmonic (THD)	<3 % (at rated power)		
Power factor at Rated power / Adjustable power factor	> 0.99 / 0.8 leading–0.8 lagging		
Feed-in phases / Connection phases	3 / 3-PE		
<b>Efficiency</b>			
Max. efficiency	98.50 %		
European efficiency	98.10 %		
<b>Protection &amp; Function</b>			
Grid monitoring	Yes		

Parameter	SG15RT	SG17RT	SG20RT
DC reverse connection protection		Yes	
AC short-circuit protection		Yes	
Leakage current protection		Yes	
Surge Protection		DC Type II / AC Type II	
Ground fault monitoring		Yes	
DC switch		Yes	
PV String current monitoring		Yes	
Arc fault circuit interrupter (AFCI)		optional	
PID recovery function		Yes	
Protective Class		I	
Oversoltage Category		DC II/AC III	
Active Anti-Islanding Method		Frequency Shift	
<b>General Data</b>			
Dimensions (W x H x D)		370 mm x 480 mm x 195 mm	
Mounting method		Wall-mounting bracket	
Weight		21 kg	
Topology		Transformerless	
Degree of protection		IP65	
Night power consumption		<6W	
Corrosion		C5	
Operating ambient temperature range		-25°C to +60°C(AU: Derating when the temperature exceeds 40°C)	

Parameter	SG15RT	SG17RT	SG20RT
Allowable relative humidity range (non-condensing)		0–100 %	
Cooling method		Smart forced air cooling	
Max. operating altitude		4000 m	
Display		LED	
Communication		WLAN / Ethernet / RS485 / DI / DO	
DC connection type		MC4 (Max. 6 mm <sup>2</sup> )	
AC connection type		Plug and play	
Grid Compliance		IEC / EN 61000-6-1/2/3/4, IEC 61000-3-2/3/11/12, IEC / EN62109-1/2, IEC 61727, IEC 62116, IEC 61683, IEC 60068-2-1/2/14/30/64/27, IEC TS 62910 , EN50530, AS/NZS 4777.2:2020, VDE-AR-N-4105, DIN VDE0126-1-1/A1, EN50549-1, DEWA, VFR 2019, UTE C15-712-1, PSE NC RfG, UNE 206006/7 IN, MEA/PEA, G98, UNE 217002:2020, NTS V2 TypeA	
Compliance(AU)		IEC / EN 61000-6-1/2/3/4, IEC 61000-3-2/3/11/12, IEC / EN62109-1/2, IEC 61727, IEC 62116, IEC 61683, IEC 60068-2-1/2/14/30/64/27, IEC TS 62910 , EN50530, AS/NZS 4777.2:2020, VDE-AR-N-4105, DIN VDE0126-1-1/A1, EN50549-1, DEWA, VFR 2019, UTE C15-712-1, PSE NC RfG, NTS 2.0, UNE 206006/7 IN, UNE 217002, MEA/PEA, G98	
Grid Support		LVRT, HVRT, active & reactive power control and power ramp rate control	
Country of manufacture		China	

(1) The inverter enters standby state when the input voltage ranges between 1,000 V and 1,100 V. If the maximum DC voltage in the system can exceed 1,000 V, the MC4 connectors included in the scope of delivery must not be used. In this case MC4-Evo2 connectors must be used.

(2) Please note the min. voltage without MPP tracker derating is 303V (+5%) for SG10/15/20RT and 236V(+5%) for SG5.0/7.0/8.0RT @AC230V 12.5A.

(4) Input voltage exceeding the MPPT operating voltage range triggers inverter protection.

(5) Please refer to the user manual for the full load MPPT voltage range.

(6) The“MPPT Voltage Range for Rated Power” for the MENA region can be found in the TI document. Please contact Sungrow for further details.

Parameter	SG5.0RT-P2	SG6.0RT-P2
<b>Input (DC)</b>		
Recommended max. PV input power	7.5 kWp <sup>(1)</sup>	9.0 kWp <sup>(2)</sup>
Max. PV input voltage <sup>(5)</sup>	1100 V <sup>(3)</sup>	
Min. PV input voltage / Start-up input voltage	180 V / 180 V for "AU", 160 V / 180 V for others	
Rated input voltage	600 V	
MPPT operating voltage range <sup>(6)</sup>	160 V–1000 V <sup>(4)</sup>	
MPPT voltage range for rated power	260V-850V <sup>(8)</sup>	320V - 850V <sup>(8)</sup>
No. of independent MPP trackers	2	
No. of of PV strings per MPPT	1 / 1	
Max. PV input current	32 A (16 A / 16 A)	
Max. DC short-circuit current	40 A (20 A / 20 A)	
<b>Output (AC)</b>		
Rated AC output power	5000 W	6000 W
Max. AC output apparent power	5000 VA for "AU", "BE", "DE", 5500 VA for others	6000 VA for "AU", "BE", "DE", 6600 VA for others
Rated AC output apparent power	5000 VA for "AU", "BE", "DE", 5500 VA for others	6000 VA for "AU", "BE", "DE", 6600 VA for others
Max. AC output current	7.6 A for "AU", 8.3 A for others	10 A
Rated AC output current(at 230V)(AU)	7.2 A	/

Parameter	SG5.0RT-P2	SG6.0RT-P2
Rated AC voltage	3 / N / PE, 220 V / 380 V	
	3 / N / PE, 230 V / 400 V	
	3 / N / PE, 240 V / 415 V	
AC voltage range	180 V – 276 V / 311 V - 478 V for "AU", 175 V–276 V / 304 V–478 V for others	
Rated grid frequency / Grid frequency range	50 Hz / (45 Hz–55 Hz)	
	60 Hz / (55 Hz–65 Hz)	
Harmonic (THD)	< 3 % (at rated power)	
Power factor at nominal power / Adjustable power factor	> 0.99 / 0.8 leading – 0.8 lagging	
Feed-in phases / connection phases	3 / 3–PE	
<b>Efficiency</b>		
Max. efficiency	98.30 %	98.30 %
European efficiency	97.20 %	97.40 %
<b>Protection &amp; Function</b>		
Grid monitoring	Yes	
DC reverse connection protection	Yes	
AC short-circuit protection	Yes	
Leakage current protection	Yes	
Surge Protection	DC Type II / AC Type II	
DC switch	Yes	
Arc fault circuit interrupter (AFCI)	Yes	
PID recovery function	Yes	

Parameter	SG5.0RT-P2	SG6.0RT-P2
Optimizer compatibility <sup>(7)</sup>		Optional
Protective Class		I
Overtoltage Category		DC II/AC III
Active Anti-Islanding Method		Frequency Shift
<b>General Data</b>		
Dimensions (W x H x D)	370 mm x 480 mm x 195 mm	
Weight	18 kg	
Mounting method	Wall-mounting bracket	
Topology	Transformerless	
Degree of protection	IP65	
Night power consumption(IN)	1 W	
Corrosion(AU)	C5	
Operating ambient temperature range	-25°C to +60°C(AU: Derating when the temperature exceeds 40°C)	
Allowable relative humidity range (non-condensing)	0–100 %	
Max. operating altitude	4000 m	
Cooling method	Natural cooling	
Display	LED	
Communication	WLAN / Ethernet / RS485 / DI / DO	
DC connection type	MC4 (Max. 6 mm <sup>2</sup> )/ MC4 Compatible Connector(Max. 6 mm <sup>2</sup> )	
AC connection type	Plug and play	
Grid Compliance	IEC / EN 61000-6-1/2/3/4, IEC 61000-3-2/3/11/12, IEC / EN62109-1/2, IEC 61727, IEC 62116, IEC 61683, IEC 60068-2-1/2/14/30/64/27, IEC TS 62910 , EN50530, AS/NZS 4777.2:2020, VDE-AR-N-4105, DIN	

Parameter	SG5.0RT-P2	SG6.0RT-P2
	VDE0126-1-1/A1, EN50549-1, DEWA, VFR 2019, UTE C15-712-1, PSE NC RfG, NTS 2.0, UNE 206006/7 IN, UNE 217002, MEA/PEA, G98	
Grid Compliance(AU)	IEC 62109-1/2, AS/NZS 4777.2: 2020	
Grid Compliance(IN)	PORTARIA Nº 140, DE 21 DE MARÇO DE 2022, EC/EN 62109-1/-2, IEC/EN 61000-6-1/-2/-3/-4 EMC, IEC 61727, IEC 62116, IEC 61683, EN 50530, IEC 60068-1/-2/-14/-27/-30/-64, IEC 61000-3-2:2006 IEC/ EN - 61000-3-12, IEC 60529 IP	
Country of manufacture	China	

(1)The max. output power per MPPT is 5.5kW.

(2)The max. output power per MPPT is 6.6kW.

(3) The inverter enters standby state when the input voltage ranges between 1,000 V and 1,100 V. If the maximum DC voltage in the system can exceed 1,000 V, the MC4 connectors included in the scope of delivery must not be used. In this case MC4-Evo2 connectors must be used.

(4) Please note the min. voltage without MPP tracker derating is 303V (+5%) for SG10/15/20RT-P2 and 236V(+5%) for SG5.0/7.0/8.0RT-P2 @AC230V 12.5A.

(5) Input voltage exceeding the MPPT operating voltage range triggers inverter protection.

(6) Please refer to the user manual for the full load MPPT voltage range.

(7) For optimizer compatibility, please consult Sungrow before placing an order.

(8) The“MPPT Voltage Range for Rated Power” for the MENA region can be found in the TI document. Please contact Sungrow for further details.

Parameter	SG7.0RT-P2	SG8.0RT-P2
<b>Input (DC)</b>		
Recommended max. PV input power	10.5 kWp <sup>(1)</sup>	12 kWp <sup>(2)</sup>
Max. PV input voltage <sup>(5)</sup>	1100 V <sup>(3)</sup>	
Min. PV input voltage / Start-up input voltage	180 V / 180 V for "AU", 160 V / 180 V for others	
Rated input voltage	600 V	

Parameter	SG7.0RT-P2	SG8.0RT-P2
MPPT operating voltage range <sup>(6)</sup>	160 V–1000 V <sup>(4)</sup>	
MPPT voltage range for rated power	260V-850V <sup>(8)</sup>	310V - 850V <sup>(8)</sup>
No. of independent MPP trackers	2	
No. of PV strings per MPPT	2 / 1	
Max. PV input current	48 A (32 A / 16 A)	
Max. DC short-circuit current	60 A (40 A / 20 A)	
<b>Output (AC)</b>		
Rated AC output power	6999 W for "AU", 7000 W for others	8000 W
Max. AC output apparent power	6999 VA for "AU", 7000 VA for "BE", "DE", 7700 VA for others	8000 VA for "AU", "BE", "DE", 8800 VA for others
Rated AC output apparent power	6999 VA for "AU", 7000 VA for "BE", "DE", 7700 VA for others	8000 VA for "AU", "BE", "DE", 8800 VA for others
Max. AC output current	10.6 A for "AU", 11.7 A for others	12.2 A for "AU", 13.3 A for others
Rated AC output current(at 230V)(AU)	10.1 A	11.6 A
Rated AC voltage	3 / N / PE, 220 V / 380 V	
	3 / N / PE, 230 V / 400 V	
	3 / N / PE, 240 V / 415 V	
AC voltage range	180 V – 276 V / 311 V - 478 V for "AU", 175 V–276 V / 304 V–478 V for others	
Rated grid frequency / Grid frequency range	50 Hz / (45 Hz–55 Hz)	
	60 Hz / (55 Hz–65 Hz)	

Parameter	SG7.0RT-P2	SG8.0RT-P2
Harmonic (THD)	< 3 % (at rated power)	
Power factor at nominal power / Adjustable power factor	> 0.99 / 0.8 leading – 0.8 lagging	
Feed-in phases / AC connection	3 / 3–PE	
<b>Efficiency</b>		
Max. efficiency	98.30 %	98.30 %
European efficiency	97.60 %	97.70 %
<b>Protection &amp; Function</b>		
Grid monitoring	Yes	
DC reverse connection protection	Yes	
AC short-circuit protection	Yes	
Leakage current protection	Yes	
Surge protection	DC Type II, AC Type II	
DC switch	Yes	
Arc fault circuit interrupter (AFCI)	Yes	
PID recovery function	Yes	
Optimizer compatibility <sup>(7)</sup>	Optional	
Protective Class	I	
Overvoltage Category	DC II/AC III	
Active Anti-Islanding Method	Frequency Shift	
<b>General Data</b>		
Dimensions (W x H x D)	370 mm x 480 mm x 195 mm	
Weight	18 kg	

Parameter	SG7.0RT-P2	SG8.0RT-P2
Mounting method	Wall-mounting bracket	
Topology	Transformerless	
Degree of protection	IP65	
Night power consumption(IN)	1 W	
Corrosion(AU)	C5	
Operating ambient temperature range	-25°C to +60°C(AU: Derating when the temperature exceeds 40°C)	
Allowable relative humidity range (non-condensing)	0–100 %	
Cooling method	Natural cooling	
Max. operating altitude	4000 m	
Display	LED	
Communication	WLAN / Ethernet / RS485 / DI / DO	
DC connection type	MC4 (Max. 6 mm <sup>2</sup> )/ MC4 Compatible Connector(Max. 6 mm <sup>2</sup> )	
AC connection type	Plug and play	
Grid Compliance	IEC / EN 61000-6-1/2/3/4, IEC 61000-3-2/3/11/12, IEC / EN62109-1/2, IEC 61727, IEC 62116, IEC 61683, IEC 60068-2-1/2/14/30/64/27, IEC TS 62910, EN50530, AS/NZS 4777.2:2020, VDE-AR-N-4105, DIN VDE0126-1-1/A1, EN50549-1, DEWA, VFR 2019, UTE C15-712-1, PSE NC RfG, NTS 2.0, UNE 206006/7 IN, UNE 217002, MEA/PEA, G98	
Grid Compliance(AU)	IEC 62109-1/2, AS/NZS 4777.2: 2020	
Grid Compliance(IN)	PORTARIA Nº 140, DE 21 DE MARÇO DE 2022, EC/EN 62109-1/-2, IEC/EN 61000-6-1/-2/-3/-4 EMC, IEC 61727, IEC 62116, IEC 61683, EN 50530, IEC 60068-1/-2/-14/-27/-30/-64, IEC 61000-3-2:2006 IEC/ EN - 61000-3-12, IEC 60529 IP	
Country of manufacture	China	

- (1) The max. output power per MPPT is 7.7kW.
- (2) The max. output power per MPPT is 8.8kW.
- (3) The inverter enters standby state when the input voltage ranges between 1,000 V and 1,100 V. If the maximum DC voltage in the system can exceed 1,000 V, the MC4 connectors included in the scope of delivery must not be used. In this case MC4-Evo2 connectors must be used.
- (4) Please note the min. voltage without MPP tracker derating is 303V (+5%) for SG10/15/20RT-P2 and 236V(+5%) for SG5.0/7.0/8.0RT-P2 @AC230V 12.5A.
- (5) Input voltage exceeding the MPPT operating voltage range triggers inverter protection.
- (6) Please refer to the user manual for the full load MPPT voltage range.
- (7) For optimizer compatibility, please consult Sungrow before placing an order.
- (8) The "MPPT Voltage Range for Rated Power" for the MENA region can be found in the TI document. Please contact Sungrow for further details.

Parameter	SG10RT-P2	SG12RT-P2
<b>Input (DC)</b>		
Recommended max. PV input power	15.0 kWp <sup>(1)</sup>	18.0 kWp <sup>(2)</sup>
Max. PV input voltage <sup>(5)</sup>	1100 V <sup>(3)</sup>	
Min. PV input voltage / Start-up input voltage	180 V / 180 V for "AU", 160 V / 180 V for others	
Rated input voltage	600 V	
MPPT operating voltage range <sup>(6)</sup>	160 V–1000 V <sup>(4)</sup>	
MPPT voltage range for rated power	320V-850V <sup>(8)</sup>	400V - 850V <sup>(8)</sup>
No. of independent MPP trackers	2	
No. of PV strings per MPPT	2 / 1	
Max. PV input current	48 A (32 A / 16 A)	
Max. DC short-circuit current	60 A (40 A / 20 A)	

Parameter	SG10RT-P2	SG12RT-P2
<b>Output (AC)</b>		
Rated AC output power	9999 W for "AU", 10000 W for others	12000 W
Max. AC output apparent power	10000 VA for "BE", "DE", 9999 VA for "AU", 11000 VA for others	12000 VA for "AU", "BE", "DE", 13200 VA for others
Rated AC output apparent power	10000 VA for "BE", "DE", 9999 VA for "AU", 11000 VA for others	12000 VA for "AU", "BE", "DE", 13200 VA for others
Max. AC output current	15.2 A for "AU" □ 16 A for "JO" □ 16.7 A for others	20.0 A
Rated AC output current(at 230V)(AU)	14.5 A	/
Rated AC voltage	3 / N / PE, 220 V / 380 V	
	3 / N / PE, 230 V / 400 V	
	3 / N / PE, 240 V / 415 V	
AC voltage range	180 V – 276 V / 311 V - 478 V for "AU", 175 V–276 V / 304 V–478 V for others	
Rated grid frequency / Grid frequency range	50 Hz / (45 Hz–55 Hz)	
	60 Hz / (55 Hz–65 Hz)	
Harmonic (THD)	< 3 % (at rated power)	
Power factor at nominal power / Adjustable power factor	> 0.99 / 0.8 leading–0.8 lagging	
Feed-in phases / AC connection	3 / 3–PE	
<b>Efficiency</b>		
Max. efficiency	98.30 %	98.30 %
European efficiency	97.80 %	97.90 %
<b>Protection &amp; Function</b>		
Grid monitoring	Yes	

Parameter	SG10RT-P2	SG12RT-P2
DC reverse connection protection		Yes
AC short circuit protection		Yes
Leakage current protection		Yes
Surge protection		DC Type II / AC Type II
DC switch		Yes
Arc fault circuit interrupter (AFCI)		Yes
PID recovery function		Yes
Optimizer compatibility <sup>(7)</sup>		Optional
Protective Class		I
Overtoltage Category		DC II/AC III
Active Anti-Islanding Method		Frequency Shift
<b>General Data</b>		
Dimensions (W x H x D)		370 mm x 480 mm x 195 mm
Weight		18 kg
Mounting method		Wall-mounting bracket
Topology		Transformerless
Degree of protection		IP65
Operating ambient temperature range		-25°C to +60°C(AU: Derating when the temperature exceeds 40°C)
Allowable relative humidity range (non-condensing)		0–100 %
Cooling method		Natural cooling
Max. operating altitude		4000 m
Display		LED

Parameter	SG10RT-P2	SG12RT-P2
Communication	WLAN / Ethernet / RS485 / DI / DO	
DC connection type	MC4 (Max. 6 mm <sup>2</sup> )/ MC4 Compatible Connector(Max. 6 mm <sup>2</sup> )	
AC connection type	Plug and play	
Grid Compliance	IEC / EN 61000-6-1/2/3/4, IEC 61000-3-2/3/11/12, IEC / EN62109-1/2, IEC 61727, IEC 62116, IEC 61683, IEC 60068-2-1/2/14/30/64/27, IEC TS 62910 , EN50530, AS/NZS 4777.2:2020, VDE-AR-N-4105, DIN VDE0126-1-1/A1, EN50549-1, DEWA, VFR 2019, UTE C15-712-1, PSE NC RfG, NTS 2.0, UNE 206006/7 IN, UNE 217002, MEA/PEA, G98	
Grid Compliance(AU)	IEC 62109-1/2, AS/NZS 4777.2: 2020	
Grid Compliance(IN)	PORTARIA N° 140, DE 21 DE MARÇO DE 2022, EC/EN 62109-1/-2, IEC/EN 61000-6-1/-2/-3/-4 EMC, IEC 61727, IEC 62116, IEC 61683, EN 50530, IEC 60068-1/-2/-14/-27/-30/-64, IEC 61000-3-2:2006 IEC/ EN - 61000-3-12, IEC 60529 IP	
Country of manufacture	China	

(1)The max. output power per MPPT is 11kW.

(2)The max. output power per MPPT is 13.2kW.

(3) The inverter enters standby state when the input voltage ranges between 1,000 V and 1,100 V. If the maximum DC voltage in the system can exceed 1,000 V, the MC4 connectors included in the scope of delivery must not be used. In this case MC4-Evo2 connectors must be used.

(4) Please note the min. voltage without MPP tracker derating is 303V (+5%) for SG10/15/20RT-P2 and 236V(+5%) for SG5.0/7.0/8.0RT-P2 @AC230V 12.5A.

(5) Input voltage exceeding the MPPT operating voltage range triggers inverter protection.

(6) Please refer to the user manual for the full load MPPT voltage range.

(7) For optimizer compatibility, please consult Sungrow before placing an order.

(8) The“MPPT Voltage Range for Rated Power” for the MENA region can be found in the TI document. Please contact Sungrow for further details.

Parameter	SG15RT-P2	SG17RT-P2	SG20RT-P2
<b>Input (DC)</b>			
Recommended max. PV input power	22.5 kWp <sup>(1)</sup>	25.5 kWp <sup>(1)</sup>	30.0 kWp <sup>(1)</sup>
Max. PV input voltage <sup>(5)</sup>	1100 V <sup>(2)</sup>		
Min. PV input voltage / Start-up input voltage	180 V / 180 V for "AU", 160 V / 180 V for others		
Rated input voltage	600 V		
MPPT operating voltage range <sup>(6)</sup>	160 V–1000 V <sup>(3)</sup>		
MPPT voltage range for rated power	380V–850V <sup>(8)</sup>	365V–850V <sup>(8)</sup>	430V–850V <sup>(8)</sup>
No. of independent MPP trackers	2		
No. of PV strings per MPPT	2 / 2	2 / 2 <sup>(4)</sup>	
Max. PV input current	64 A (32 A / 32 A)		
Max. DC short-circuit current	80 A (40 A / 40 A)		
<b>Output (AC)</b>			
Rated AC output power	15000 W	17000 W	20000 W
Max. AC output apparent power	15000 VA for "AU", "BE", "DE", 16500 VA for others	17000 VA for "AU", "BE", "DE", 18700 VA for others	20000 VA for "AU", "BE", "DE", 22000 VA for others
Rated AC output apparent power	10000 VA for "BE", "DE", 9999 VA for "AU", 11000 VA for others	12000 VA for "AU", "BE", "DE", 13200 VA for others	
Max. AC output current	22.7 A for "AU", 25 A for others	28.3 A	30.3 A for "AU", 31.9 A for others

Parameter	SG15RT-P2	SG17RT-P2	SG20RT-P2
Rated AC output current(at 230V)(AU)	21.7 A	/	29 A
		3 / N / PE, 220 V / 380 V	
Rated AC voltage		3 / N / PE, 230 V / 400 V	
		3 / N / PE, 240 V / 415 V	
AC voltage range		175 V–276 V / 304 V–478 V	
Rated grid frequency / Grid frequency range		50 Hz / (45 Hz–55 Hz) 60 Hz / (55 Hz–65 Hz)	
Harmonic (THD)		< 3 % (at nominal power)	
Power factor at nominal power / Adjustable power factor		> 0.99 / 0.8 leading–0.8 lagging	
Feed-in phases / AC connection		3 / 3	
<b>Efficiency</b>			
Max. efficiency		98.30 %	
European efficiency		97.90 %	
<b>Protection &amp; Function</b>			
Grid monitoring		Yes	
DC reverse connection protection		Yes	
AC short-circuit protection		Yes	
Leakage current protection		Yes	
Surge protection		DC Type II / AC Type II	
DC switch		Yes	
Arc fault circuit interrupter (AFCI)		Yes	
PID recovery function		Yes	

Parameter	SG15RT-P2	SG17RT-P2	SG20RT-P2
Optimizer compatibility <sup>(7)</sup>		Optional	
Protective Class		I	
Overvoltage Category		DC II/AC III	
Active Anti-Islanding Method		Frequency Shift	
<b>General Data</b>			
Dimensions (W x H x D)		370 mm x 480 mm x 195 mm	
Weight		22 kg	
Mounting method		Wall-mounting bracket	
Topology		Transformerless	
Degree of protection		IP65	
Operating ambient temperature range		-25°C to +60°C(AU: Derating when the temperature exceeds 40°C)	
Allowable relative humidity range (non-condensing)		0–100 %	
Cooling method		Smart forced air cooling	
Max. operating altitude		4000 m	
Display		LED	
Communication		WLAN / Ethernet / RS485 / DI / DO	
DC connection type		MC4 (Max. 6 mm <sup>2</sup> )	
AC connection type		Plug and play	
Grid Compliance		IEC / EN 61000-6-1/2/3/4, IEC 61000-3-2/3/11/12, IEC / EN62109-1/2, IEC 61727, IEC 62116, IEC 61683, IEC 60068-2-1/2/14/30/64/27, IEC TS 62910 , EN50530, AS/NZS 4777.2:2020, VDE-AR-N-4105, DIN VDE0126-1-1/A1, EN50549-1, DEWA, VFR 2019, UTE C15-712-1, PSE NC RfG, NTS 2.0, UNE 206006/7 IN, UNE 217002, MEA/PEA, G98	
Grid Compliance(AU)		IEC 62109-1/2, AS/NZS 4777.2: 2020	

Parameter	SG15RT-P2	SG17RT-P2	SG20RT-P2
Grid Compliance(IN)	PORTARIA Nº 140, DE 21 DE MARÇO DE 2022, EC/EN 62109-1/-2, IEC/EN 61000-6-1/-2/-3/-4 EMC, IEC 61727, IEC 62116, IEC 61683, EN 50530, IEC 60068-1/-2/-14/-27/-30/-64, IEC 61000-3-2:2006 IEC/ EN - 61000-3-12, IEC 60529 IP		
Country of manufacture	China		

(1)The max. output power per MPPT is 15.5kW.

(2) The inverter enters standby state when the input voltage ranges between 1,000 V and 1,100 V. If the maximum DC voltage in the system can exceed 1,000 V, the MC4 connectors included in the scope of delivery must not be used. In this case MC4-Evo2 connectors must be used.

(3) Please note the min. voltage without MPP tracker derating is 303V (+5%) for SG10/15/20RT-P2 and 236V(+5%) for SG5.0/7.0/8.0RT-P2 @AC230V 12.5A.

(4) The maximum power for a single MPPT is 15.5kW.

(5) Input voltage exceeding the MPPT operating voltage range triggers inverter protection.

(6) Please refer to the user manual for the full load MPPT voltage range.

(7) For optimizer compatibility, please consult Sungrow before placing an order.

(8) The“MPPT Voltage Range for Rated Power” for the MENA region can be found in the TI document. Please contact Sungrow for further details.

## 10.2 Quality Assurance

When product faults occur during the warranty period, SUNGROW will provide free service or replace the product with a new one.

The software security update period for this product aligns with the warranty period. During the warranty, security patches or updates will be provided if any vulnerabilities or compatibility issues are identified.

### Evidence

During the warranty period, the customer shall provide the product purchase invoice and date. In addition, the trademark on the product shall be undamaged and legible. Otherwise, SUNGROW has the right to refuse to honor the quality guarantee.

### Conditions

- After replacement, unqualified products shall be processed by SUNGROW.

- The customer shall give SUNGROW a reasonable period to repair the faulty device.

### **Exclusion of Liability**

In the following circumstances, SUNGROW has the right to refuse to honor the quality guarantee:

- The free warranty period for the whole machine/components has expired.
- The device is damaged during transport.
- The device is incorrectly installed, refitted, or used.
- The device operates in harsh conditions beyond those described in this manual.
- The fault or damage is caused by installation, repairs, modification, or disassembly performed by a service provider or personnel not from SUNGROW.
- The fault or damage is caused by the use of non-standard or non-SUNGROW components or software.
- The installation and use range are beyond stipulations of relevant international standards.
- The damage is caused by unexpected natural factors.

For faulty products in any of above cases, if the customer requests maintenance, paid maintenance service may be provided based on the judgment of SUNGROW.

Product data such as product dimensions are subject to change without prior notice. The latest documentation from SUNGROW should take precedence in case of any deviation.

## **10.3 Contact Information**

In case of questions about this product, please contact us. We need the following information to provide you the best assistance:

- Model of the device
- Serial number of the device
- Fault code/name
- Brief description of the problem

For detailed contact information, please visit: <https://en.SUNGROWpower.com/contactUS>

Sungrow Power Supply Co., Ltd.

[www.sungrowpower.com](http://www.sungrowpower.com)